

ALTERNATION HISTORY RECORDS 变更记录

Date 日期	Version 版本	Mark 标记	Page 页码	Description 描述	Drafter 制定者	Approver 审批者
201904-12	A	/	9	InitialIssue(首次发行)	汤勋	常斯琴

Part Numbering System

ATP

Series Name:
ATP:Thick-film Power
Type Low Ohm Chip
Resistors

12

TypeInch (mm)
03-0603(1608)
05-0805(2012)
06-1206(3216)
10-1210(3225)
0A-2010(5025)
12-2512(6432)

J

Tolerance
F= $\pm 1.0\%$
J= $\pm 5.0\%$
P=Jumper

A

Package
A=4Kpcs/7"Reel
B=5Kpcs/7"Reel
C=10Kpcs/7"Reel

10K

Resistance
R02=0.02 Ω
R15=0.15 Ω

1. Features

- High power rating to 2W and low TCR.
- Low resistance and high precision (1%).
- Excellent reliability and suitable cost.
- Suitable for lead free soldering.
- Meet AEC-Q200, RoHS compliant & Halogen Free.

2.Applications

- Consumer electronics, M/B.
- Battery pack, BTC.
- Notebook, Tablet PC.
- Portable Device, Electronic Equipment.

3.Dimension and Construction

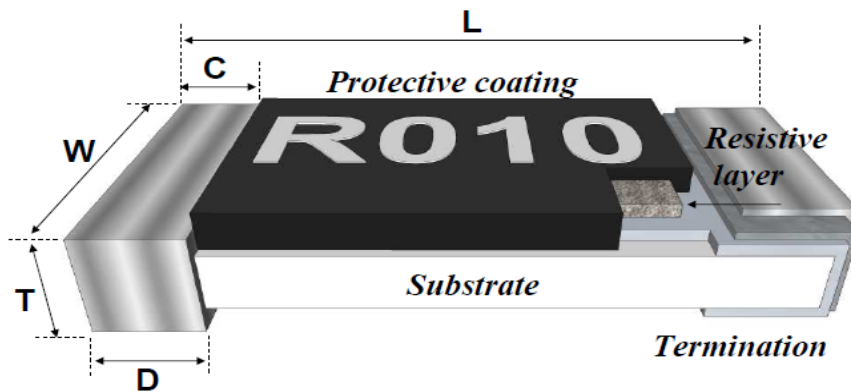

Unit : mm

Type	L	W	C	D	T
ATP03	1.60±0.10	0.80±0.10	0.30±0.20	0.30±0.20	0.45±0.10
ATP05	2.00±0.10	1.25±0.10	0.40±0.20	0.40±0.20	0.50±0.10
ATP06	3.10±0.10	1.60±0.10	0.50±0.25	0.50±0.25	0.55±0.10
ATP12	3.10±0.10	2.60±0.10	0.50±0.25	0.50±0.25	0.55±0.10
ATP0A	5.00±0.20	2.50±0.20	0.65±0.25	0.60±0.25	0.60±0.10
ATP25	6.40±0.20	3.10±0.20	0.60±0.25	1.80±0.25	0.60±0.15

4. Power Derating Curve

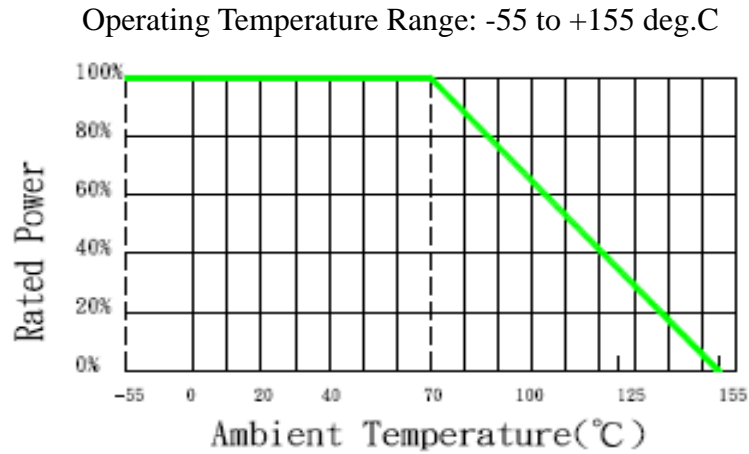

5. Rating

High Power		Power Rating at 70°C	Max. RCWV (mV)	Max. Overload Voltage (mV)	Resistance Tolerance (%)	Temperature Coefficient (TCR; ppm/°C)	Resistance Range (mΩ)		Standard Resistance Values
Type	Size						Min.	Max.	
ATP03	0603	1/4W	477	1066	±1、±5	±250	50	91	E-24
						±150*	100	910	
ATP05	0805	1/3W	551	1232	±1、±5	±200	50	91	
						±100*	100	910	
ATP06	1206	1/2W	675	1508	±1、±5	±100*	50	91	
						±100	100	910	
ATP12	1210	1/2W	675	1508	±1、±5	±100	50	910	
ATP0A	2010	1W	954	2133	±1、±5	±100*	50	91	
						±100	100	910	
ATP25	2512	2W	1349	3017	±1、±5	±100*	50	91	
						±100	100	910	

*Temperature 25~-55°C, 200ppm for 0603, 150ppm for 0805.

*Temperature 25~-55°C, 150ppm for 1206、2010、2512

Note : (i) Solder-pad and trace size should be >300 mm² and board surface temperature should not exceed 105°C when applying rated power.

(ii) $E = (P \times R)^{1/2}$ E : Working Voltage(V) , P : Rated Power(W) , R : Resistance Value(Ω)

Example :

ATP12FAR100

→2512 size, tolerance 1%, plastic tape, 2W, 100mΩ, Aec-Q200.

ATP06JBR05

→1206 size, tolerance 5%, paper tape, 1/2W, 50mΩ, standard.

7. Marking/Soldering

Resistance value identify :

0805/1206/1210/2010/2512

Top Marking. (4 Digits marking to identify the resistance value.)

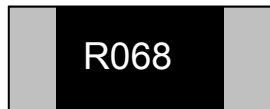

R068=68mΩ , R120=120mΩ

0603

Top Marking. (3 Digits marking to identify the resistance value.)



R12=120mΩ , 68M=68mΩ

Soldering Reference :

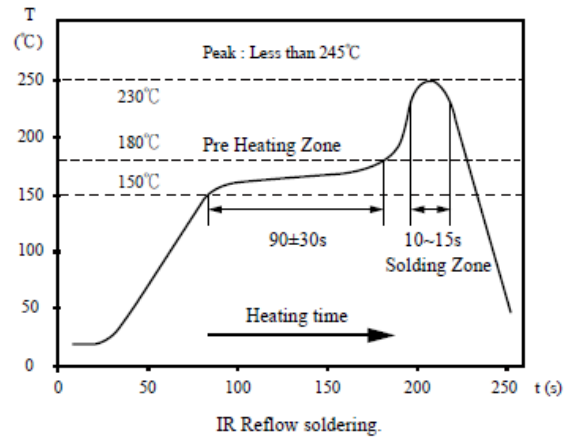
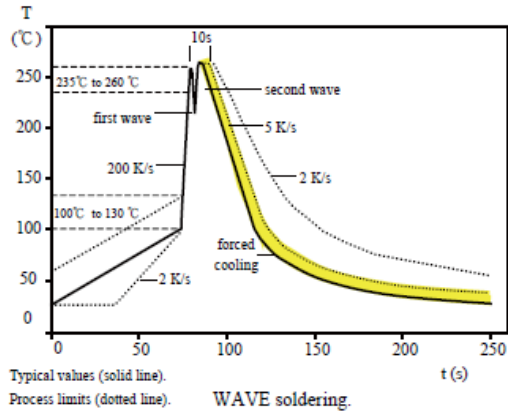

Recommend Solder Pad Dimensions :

Type	W	D	L
ATP03	0.90	1.00	3.00
ATP05	1.30	1.15	3.50
ATP06	1.80	1.30	4.70
ATP12	3.00	1.30	4.70
ATP0A	3.00	1.50	6.80
ATP25	3.70	2.45	7.60

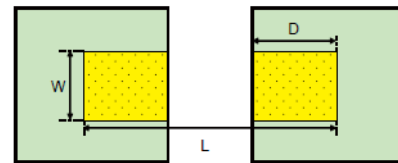

Unit:mm

8. Reliability Performance (AEC-Q200)

Test Item	Specification	Test Method (AEC-Q200. IEC 60115)
*DC Resistance	F : $\pm 1\%$; J : $\pm 5\%$	AEC-Q200 TABLE 7.1 IEC 60115-1 / JIS C 5201-1 , Clause 4.5 Measure the resistance Value.
High Temperature Exposure (Storage)	J : $\Delta R \leq \pm(3\%+0.5m\Omega)$ F : $\Delta R \leq \pm(1\%+0.5m\Omega)$	AEC-Q200 TABLE 7.3 1000 hrs. @ T=125°C. Unpowered. Measurement at 24 ± 2 hours after test conclusion.
*Temperature Cycling	J : $\Delta R \leq \pm(1\% + 1m\Omega)$ F : $\Delta R \leq \pm(0.5\% + 1m\Omega)$ No mechanical damage.	AEC-Q200 TABLE 7.4 1000 Cycles (-55°C to +125°C). Measurement at 24 ± 2 hours after test conclusion.

Moisture Resistance	J : $\Delta R \leq \pm(1\%+0.5m\Omega)$ F : $\Delta R \leq \pm(0.5\%+0.5m\Omega)$	AEC-Q200 TABLE 7.6 Test 65°C/80~100%RH/10Cycles. Measurement at 24±2 hours after test conclusion. (t=24hrs/cycle).
Biased Humidity	J : $\Delta R \leq \pm(3\%+0.5m\Omega)$ F : $\Delta R \leq \pm(1\%+0.5m\Omega)$	AEC-Q200 TABLE 7.7 1000 hours 85°C/85%RH. 10% of operating power. Measurement at 24 ±2 hours after test conclusion.
Operational Life	J : $\Delta R \leq \pm(3\%+0.5m\Omega)$ F : $\Delta R \leq \pm(1\%+0.5m\Omega)$	AEC-Q200 TABLE 7.8 Test 1000hr @ TA=125°C at specified rated power. Measurement at 24±2 hours after test conclusion.
External Visual	No visual damage and refer PDC marking code.	AEC-Q200 TABLE 7.9 Inspect device construction, marking and workmanship.
Physical Dimension	Within the spec.	AEC-Q200 TABLE 7.10 Verify physical dimensions to the applicable device detail specification.
Mechanical Shock	Within product specification tolerance and no visible damage.	AEC-Q200 TABLE 7.13 Test Peak value:100g's,Wave:Hail-sine, Duration:6ms,Velocity:12.3ft/sec.
Vibration	No mechanical damage.	AEC-Q200 TABLE 7.14 5 g's for 20 min., 12 cycles each of 3 orientations. Test from 10-2000 Hz.
*Resistance to Solder Heat	J : $\Delta R \leq \pm(1\% + 0.5m\Omega)$ F : $\Delta R \leq \pm(0.5\% + 0.5m\Omega)$ No mechanical damage.	AEC-Q200 TABLE 7.15 Solder dipping @ 270°C±5°C for 10sec.±1sec.
Thermal Shock	J : $\Delta R \leq \pm(1\% + 0.5m\Omega)$ F : $\Delta R \leq \pm(0.5\% + 0.5m\Omega)$ No mechanical damage.	AEC-Q200 TABLE 7.16 -55 to 155°C / dwell time 15min/ Max transfer time 20sec/ 300cycles.

ESD	$\Delta R \leq \pm(1\% + 0.5m\Omega)$ No mechanical damage.	AEC-Q200-002 Test contact min. 1KV.
*Solder Ability	Over 95% of termination must be covered with solder.	AEC-Q200 TABLE 7.18 a) Baking 155°C 4H, dipping 235°C 5s b) Steam 1H, dipping 215°C 5s c) Steam 1H, dipping 260°C 7s
Flammability	Refer UL-94.	AEC-Q200 TABLE 7.20 UL-94 V-0 or V-1 are acceptable
*Board Flex	J : $\Delta R \leq \pm(1\% + 1m\Omega)$ F : $\Delta R \leq \pm(0.5\% + 1m\Omega)$ No mechanical damage.	AEC-Q200 TABLE 7.21 Bending 2mm 2512.2010.1210.1206, 3mm 0805.0603.
Terminal Strength	No mechanical damage	AEC-Q200 TABLE 7.22 Force 1 Kg for 60 seconds.
*Short Time Overload	J : $\Delta R \leq \pm(2\% + 0.5m\Omega)$ F : $\Delta R \leq \pm(1\% + 0.5m\Omega)$	IEC 60115-1, Clause 4.13 5 × Rated power for 5 seconds
*Load Life Humidity	J : $\Delta R \leq \pm(3\% + 0.5m\Omega)$ F : $\Delta R \leq \pm(1\% + 0.5m\Omega)$	IEC 60115-1, Clause 4.24 40±2°C with relative humidity 90% ~ 95% D.C. rated voltage for 1.5 hours ON 30 minutes OFF. Cycle repeated 1000 hours.
*Temperature Coefficient of Resistance (TCR)	Within the spec.	IEC 60115-1, Clause 4.8 $T_1 \quad T_2$ Test temperature : 25°C ~ -55°C 25°C ~ +155°C TCR(ppm/°C) = $(R_2 - R_1) / R_1 \times 1 / (T_2 - T_1) \times 10^6$
*Load Life	J : $\Delta R \leq \pm(3\% + 0.5m\Omega)$ F : $\Delta R \leq \pm(1\% + 0.5m\Omega)$	IEC 60115-1, Clause 4.25 Rated voltage for 1.5 hours for followed by a pause 0.5 hour at 70±2°C. Cycle repeated 1000 hours.
*Insulation Resistance	Between termination and coating must over 1000MΩ	IEC 60115-1, Clause 4.6 Test voltage : 100±15V

* Normal test items for standard product.

9. PACKAGING

9.1 Peel Strength of Top Cover Tape

The peel speed shall be about 300 mm/min

The peel force of top cover tape shall be between 0.1 to 0.7N

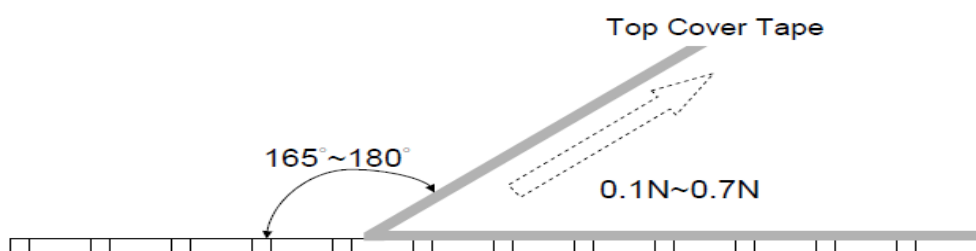

9.2 Tape Packaging Dimensions

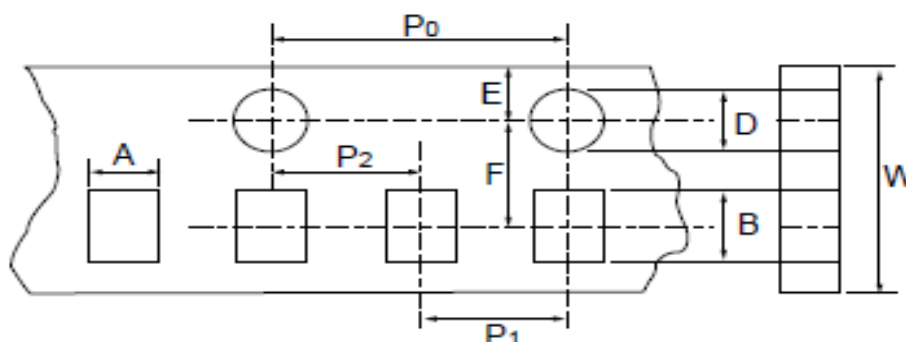

• Accumulated dimensional tolerance $40 \pm 0.2 \text{ mm}$

unit:mm

Size	A	B	W	F	E	P1	P2	P0	D
0603	1.10 ± 0.20	1.90 ± 0.20	8.00 ± 0.30	3.50 ± 0.05	1.75 ± 0.10	4.00 ± 0.10	2.00 ± 0.05	4.00 ± 0.10	$1.50 + 0.10 / -0$
0805	1.65 ± 0.20	2.40 ± 0.20	8.00 ± 0.30	3.50 ± 0.05	1.75 ± 0.10	4.00 ± 0.10	2.00 ± 0.05	4.00 ± 0.10	$1.50 + 0.10 / -0$
1206	2.00 ± 0.20	3.60 ± 0.20	8.00 ± 0.30	3.50 ± 0.05	1.75 ± 0.10	4.00 ± 0.10	2.00 ± 0.05	4.00 ± 0.10	$1.50 + 0.10 / -0$
1210	3.00 ± 0.20	3.60 ± 0.20	8.00 ± 0.30	3.50 ± 0.05	1.75 ± 0.10	4.00 ± 0.10	2.00 ± 0.05	4.00 ± 0.10	$1.50 + 0.10 / -0$
2010	2.80 ± 0.20	5.50 ± 0.20	12.00 ± 0.30	5.50 ± 0.05	1.75 ± 0.10	4.00 ± 0.10	2.00 ± 0.05	4.00 ± 0.10	$1.50 + 0.10 / -0$
2512	3.50 ± 0.20	6.70 ± 0.20	12.00 ± 0.30	5.50 ± 0.05	1.75 ± 0.10	4.00 ± 0.10	2.00 ± 0.05	4.00 ± 0.10	$1.50 + 0.10 / -0$

unit : mm

9.3 Reel Dimensions

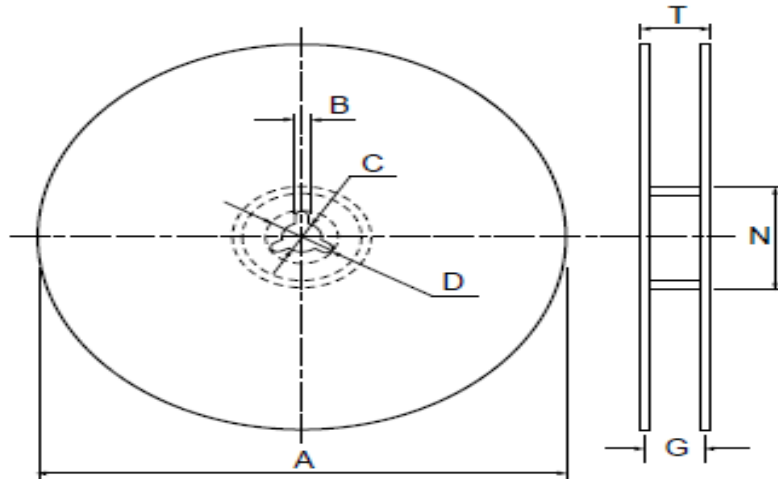

unit:mm

Size	Packaging Q'ty	A	N	C	D	B	G	T
0603	5kpcs/Reel	178.0±2.0	60.0±0.5	13.0±0.5	20(Min.)	2.0±0.5	10.0±1.5	14.9max.
0805	10kpcs/Reel	254.0±2.0	100.0±1.0	13.5±0.5	20(Min.)	2.0±0.5	10.0±1.5	14.9max.
1206	20kpcs/Reel	330.0±2.0	100.0±1.0	13.5±0.5	20(Min.)	2.0±0.5	10.0±1.5	14.9max.
2010	4kpcs/Reel	178.0±2.0	60.0±0.5	13.0±0.5	20(Min.)	2.0±0.5	13.8±1.5	16.7max.
2512	8kpcs/Reel	254.0±2.0	100.0±0.5	13.5±0.5	20(Min.)	2.0±0.5	13.8±1.5	20.0max.
	16kpcs/Reel	330.0±2.0	100.0±1.0	13.5±0.5	20(Min.)	2.0±0.5	13.8±1.5	20.0max.

10. Storage & Handling

... Products are recommended to be used up within one year as ensured shelf life.

Check solder ability in case shelf life extension is needed.

... To store products with following condition:

Temperature: 5 to 40°C ; Humidity: 20 to 70% relative humidity.