

发行日期: _____

承认书编号: _____

承认书

Approval Sheet

客户名称 Customer : _____
爱伦料号 Aillen P/N : CD11T Series
规格描述 Description : _____
客户料号 Customer P/N : _____

客户接收

接收日期: _____

接收者	检验者	确认	审核	客户盖章

供应商

编制	确认	审核	公司盖章
常斯琴	/	彭旭	

爱 伦 电 子 科 技 有 限 公 司

Aillen Electronic Technology Limited

香港:香港湾仔庄士敦道 181 号大有大厦 10 楼 1001 室
ADD:1001R.10F Taiyau Building.181 Johnston Road.Wanchai H.K
TEL: 00852-36458129 FAX: 00852-36458092
东莞:广东省东莞市东城区东莞大道 11 号环球经贸中心 A805
ADD:A805 TBA Tower NO. 11 DongGuan Road ,DongGuan,GuangDong
TEL: 0769-23124124 /88050188 FAX: 0769-23124135

<http://www.aillen.com>E-mail: skychung@aillen.com

ALTERNATION HISTORY RECORDS 变更记录

Date 日期	Version 版本	Mark 标记	Page 页码	Description 描述	Drafter 制定者	Approver 审批者
2018-01-12	A	/	22	首次发行	常斯琴	彭旭

2.Part Number System

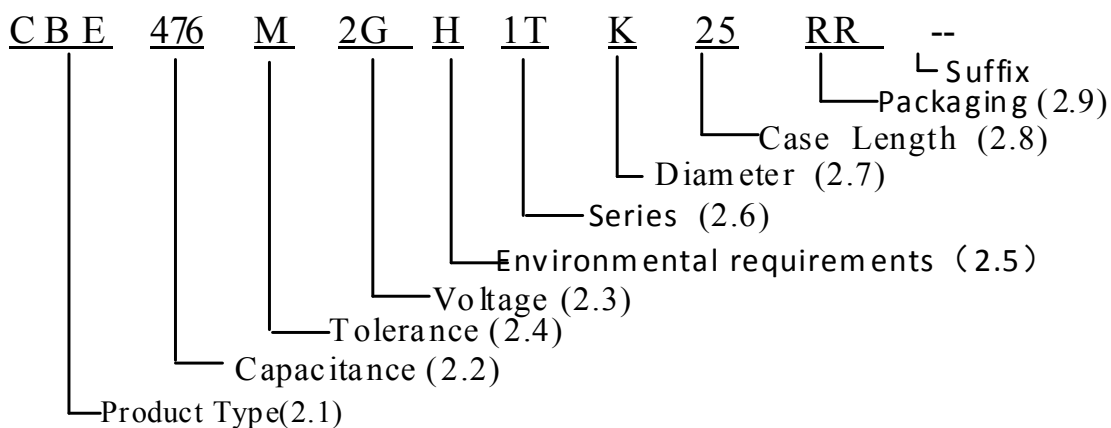

2.1 Product Type:

Code	CBE
Product Type	Radial

2.2 Capacitance code

Code	225	106	226	227
Capacitance (μF)	2.2	10	22	220

2.3 Rated voltage code

Code	0J	1A	1C	1E	1V	1H	1J	2A
Voltage (W.V.)	6.3	10	16	25	35	50	63	100

Code	2C	2D	2E	2V	2G	2W
Voltage (W.V.)	160	200	250	350	400	450

2.4 Capacitance tolerance

Code	M	V	R
Tolerance Range	±20%	-10%~+20%	0~+20%

2.5 Environmental requirements

Code	R	H
Environmental requirements	ROHS Requirements	ROHS Requirements and Halogen Free

2.6 Products Series Code:

Code	1T
Series	CD11T

2.7 Diameter

Code	D	E	F	G	I	J	K	L	N
Diameter	5	6.3	8	10	12.5	13	16	18	22

2.8 Case length

Code	11	1A	1B	20	2A	3A
length(mm)	11	11.5	12.5	20	21.5	31.5

2.9 Packaging:

Code	RR	R2	T2	TB	T3	T5
Packaging	Bulk	F8 的产品 脚距是 2.5mm 的 Bulk	Lead Pitch=2.0mm Taping	Lead Pitch=2.5mm Taping	Lead Pitch=3.5mm Taping	Lead Pitch=5.0mm Taping
Code	T7		CA	CB	CC	CD
Packaging	Lead Pitch=7.5mm Taping		Cut the feet long=3.0mm	Cut the feet long=3.5mm	Cut the feet long=4.0mm	Cut the feet long=4.5mm

注：产品切脚长度，以 A=3.0mm 开始，每增加 0.5mm，英文字向前推一位，如下表：

切脚长度(mm)	代码
3.0±0.5	CA
3.5±0.5	CB
4.0±0.5	CC
4.5±0.5	CD
5.0±0.5	CE
6.0±0.5	CG
依次类推-----	

3.Construction

Single ended type to be produced to fix the terminals to anode and cathode foil, and wind together with paper, and then wound element to be impregnated with electrolyte will be enclosed in an aluminum case. Finally sealed up tightly with end seal rubber, then finished by putting on the vinyl sleeve.

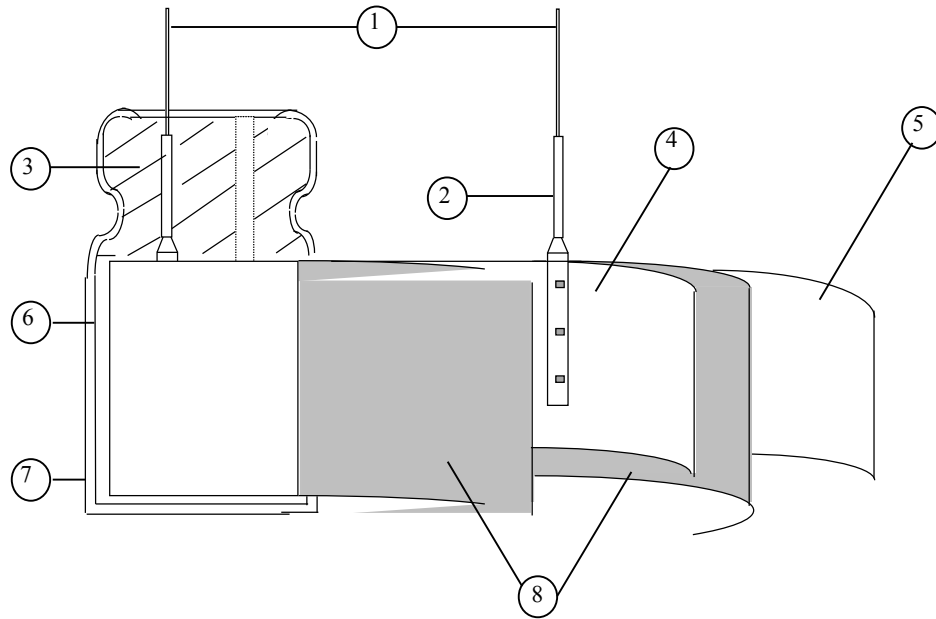

No	Component	Material
1	Lead line	Tinned CP wire (Pb Free)
2	Terminal	Aluminum wire
3	Sealing Material	Rubber
4	Al-Foil (+)	Formed aluminum foil
5	Al-Foil (-)	Etched aluminum foil or formed aluminum foil
6	Case	Aluminum case
7	Sleeve	PET
8	Separator	Electrolyte paper

4.Characteristics

Standard atmospheric conditions

Unless otherwise specified, the standard range of atmospheric conditions for making measurements and tests is as follows:

Ambient temperature	: 15°C to 35°C
Relative humidity	: 45% to 85%
Air pressure	: 86kPa to 106kPa

If there is any doubt about the results, measurement shall be made within the following conditions:

Ambient temperature	: 20°C ± 2°C
Relative humidity	: 60% to 70%
Air pressure	: 86kPa to 106kPa

Operating temperature range

The ambient temperature range at which the capacitor can be operated continuously at rated voltage is (6.3~100WV) -40°C to 105°C, (160~450WV) -25°C to 105°C.

As to the detailed information, please refer to table 1

Table 1

ITEM		PERFORMANCE									
4.1	Rated Voltage (WV)	WV (V.DC)	6.3	10	16	25	35	50	63	100	
		SV (V.DC)	8	13	20	32	44	63	79	125	
	Surge Voltage (SV)	WV (V.DC)	160	200	250	350	400	450			
		SV (V.DC)	200	250	300	400	450	500			
4.2	Nominal capacitance (Tolerance)	<p><Condition> Measuring Frequency : 120Hz ± 12Hz Measuring Voltage : Not more than 0.5Vrms Measuring Temperature : 20 ± 2°C</p> <p><Criteria> Shall be within the specified capacitance tolerance.</p>									
4.3	Leakage current	<p><Condition> Connecting the capacitor with a protective resistor (1kΩ ± 10Ω) in series for 2 minutes, and then, measure leakage current.</p> <p><Criteria> 6.3~100V: I (μA) ≤ 0.01CV or 3 (μA) whichever is greater. 160~450V: I ≤ 0.03CV + 40 (μA)</p> <p>I: Leakage current (μA) C: Capacitance (μF) V: Rated DC working voltage (V)</p>									

4.4	tan δ	<p><Condition> See 4.2 Nominal capacitance, for measuring frequency, voltage and temperature.</p> <p><Criteria></p> <table border="1" data-bbox="501 253 1453 344"> <tr> <td>Working voltage (v)</td> <td>6.3</td> <td>10</td> <td>16</td> <td>25</td> <td>35</td> <td>50</td> <td>63</td> <td>100</td> </tr> <tr> <td>tan δ (max.)</td> <td>0.26</td> <td>0.22</td> <td>0.18</td> <td>0.16</td> <td>0.14</td> <td>0.12</td> <td>0.10</td> <td>0.08</td> </tr> </table> <table border="1" data-bbox="501 383 1313 465"> <tr> <td>Working voltage (v)</td> <td>160</td> <td>200</td> <td>250</td> <td>350</td> <td>400</td> <td>450</td> </tr> <tr> <td>tan δ (max.)</td> <td>0.15</td> <td>0.20</td> <td>0.20</td> <td>0.24</td> <td>0.24</td> <td>0.24</td> </tr> </table> <p>For capacitance value >1000uF, add 0.02 per another 1000uF</p>	Working voltage (v)	6.3	10	16	25	35	50	63	100	tan δ (max.)	0.26	0.22	0.18	0.16	0.14	0.12	0.10	0.08	Working voltage (v)	160	200	250	350	400	450	tan δ (max.)	0.15	0.20	0.20	0.24	0.24	0.24										
Working voltage (v)	6.3	10	16	25	35	50	63	100																																				
tan δ (max.)	0.26	0.22	0.18	0.16	0.14	0.12	0.10	0.08																																				
Working voltage (v)	160	200	250	350	400	450																																						
tan δ (max.)	0.15	0.20	0.20	0.24	0.24	0.24																																						
4.5	Terminal strength	<p><Condition> Tensile strength of terminals Fixed the capacitor, applied force to the terminal in lead out direction for 10 ± 1 seconds. Bending strength of terminals Fixed the capacitor, applied force to bent the terminal (1~4 mm from the rubber) for 90° within 2~3 seconds, and then bent it for 90° to its original position within 2~3 seconds.</p> <table border="1" data-bbox="531 801 1412 983"> <tr> <th>Diameter of lead wire</th> <th>Tensile force N (kgf)</th> <th>Bending force N (kgf)</th> </tr> <tr> <td>0.5mm and less</td> <td>5 (0.51)</td> <td>2.5 (0.25)</td> </tr> <tr> <td>Over 0.5mm to 0.8mm</td> <td>10 (1.0)</td> <td>5 (0.51)</td> </tr> </table> <p><Criteria> No noticeable changes shall be found, no breakage or looseness at the terminal.</p>	Diameter of lead wire	Tensile force N (kgf)	Bending force N (kgf)	0.5mm and less	5 (0.51)	2.5 (0.25)	Over 0.5mm to 0.8mm	10 (1.0)	5 (0.51)																																	
Diameter of lead wire	Tensile force N (kgf)	Bending force N (kgf)																																										
0.5mm and less	5 (0.51)	2.5 (0.25)																																										
Over 0.5mm to 0.8mm	10 (1.0)	5 (0.51)																																										
4.6	Temperature characteristics	<p><Condition></p> <table border="1" data-bbox="504 1133 1407 1426"> <thead> <tr> <th>STEP</th> <th>Testing temperature(°C)</th> <th>Time</th> </tr> </thead> <tbody> <tr> <td>1</td> <td>20 ± 2</td> <td>Time to reach thermal equilibrium</td> </tr> <tr> <td>2</td> <td>(-40)-25 ± 3</td> <td>Time to reach thermal equilibrium</td> </tr> <tr> <td>3</td> <td>20 ± 2</td> <td>Time to reach thermal equilibrium</td> </tr> <tr> <td>4</td> <td>105 ± 2</td> <td>Time to reach thermal equilibrium</td> </tr> <tr> <td>5</td> <td>20 ± 2</td> <td>Time to reach thermal equilibrium</td> </tr> </tbody> </table> <p><Criteria></p> <p>a. At +105°C, capacitance measured shall be within ±20% of its original value at +20°C. tan δ shall be within the limit of Item 4.4 The leakage current measured shall not more than 8 times of its specified value.</p> <p>b. In step 5, tan δ shall be within the limit of Item 4.4 The leakage current shall not more than the specified value.</p> <p>c. At -25 °C, Impedance (Z) ratio shall not exceed the value of the following table.</p> <table border="1" data-bbox="504 1818 1485 1933"> <tr> <td>Rated Voltage (V)</td> <td>6.3</td> <td>10</td> <td>16</td> <td>25~100</td> <td>160~350</td> <td>400~420</td> <td>450</td> </tr> <tr> <td>Z-25°C / Z +20°C</td> <td>5</td> <td>4</td> <td>3</td> <td>2</td> <td>4</td> <td>6</td> <td>15</td> </tr> <tr> <td>Z-40°C / Z +20°C</td> <td>10</td> <td>8</td> <td>6</td> <td>4</td> <td>/</td> <td>/</td> <td>/</td> </tr> </table> <p>Capacitance, tan δ, and impedance shall be measured at 120Hz.</p>	STEP	Testing temperature(°C)	Time	1	20 ± 2	Time to reach thermal equilibrium	2	(-40)-25 ± 3	Time to reach thermal equilibrium	3	20 ± 2	Time to reach thermal equilibrium	4	105 ± 2	Time to reach thermal equilibrium	5	20 ± 2	Time to reach thermal equilibrium	Rated Voltage (V)	6.3	10	16	25~100	160~350	400~420	450	Z-25°C / Z +20°C	5	4	3	2	4	6	15	Z-40°C / Z +20°C	10	8	6	4	/	/	/
STEP	Testing temperature(°C)	Time																																										
1	20 ± 2	Time to reach thermal equilibrium																																										
2	(-40)-25 ± 3	Time to reach thermal equilibrium																																										
3	20 ± 2	Time to reach thermal equilibrium																																										
4	105 ± 2	Time to reach thermal equilibrium																																										
5	20 ± 2	Time to reach thermal equilibrium																																										
Rated Voltage (V)	6.3	10	16	25~100	160~350	400~420	450																																					
Z-25°C / Z +20°C	5	4	3	2	4	6	15																																					
Z-40°C / Z +20°C	10	8	6	4	/	/	/																																					

4.7	Load life test	<p><Condition> According to IEC60384-4No.4.13 methods, The capacitor is stored at a temperature of $105 \pm 2^{\circ}\text{C}$ with DC bias voltage plus the rated ripple current for 2000+48/0 hours. (The sum of DC and ripple peak voltage shall not exceed the rated working voltage) Then the product should be tested after 16 hours recovering time at atmospheric conditions. The result should meet the following table:</p> <p><Criteria> The characteristic shall meet the following requirements.</p> <table border="1" data-bbox="560 510 1455 687"> <tr> <td>Leakage current</td> <td>Value in 4.3 shall be satisfied</td> </tr> <tr> <td>Capacitance Change</td> <td>Within $\pm 20\%$ of initial value.</td> </tr> <tr> <td>$\tan \delta$</td> <td>Not more than 200%of the specified value.</td> </tr> <tr> <td>Appearance</td> <td>There shall be no leakage of electrolyte.</td> </tr> </table>	Leakage current	Value in 4.3 shall be satisfied	Capacitance Change	Within $\pm 20\%$ of initial value.	$\tan \delta$	Not more than 200%of the specified value.	Appearance	There shall be no leakage of electrolyte.
Leakage current	Value in 4.3 shall be satisfied									
Capacitance Change	Within $\pm 20\%$ of initial value.									
$\tan \delta$	Not more than 200%of the specified value.									
Appearance	There shall be no leakage of electrolyte.									
4.8	Shelf life test	<p><Condition> The capacitors are then stored with no voltage applied at a temperature of $105 \pm 2^{\circ}\text{C}$ for 1000+48/0 hours. Following this period the capacitors shall be removed from the test chamber and be allowed to stabilized at room temperature for 4~8 hours. Next they shall be connected to a series limiting resistor($1\text{k} \pm 100 \Omega$) with D.C. rated voltage applied for 30min. After which the capacitors shall be discharged, and then, tested the characteristics.</p> <p><Criteria> The characteristic shall meet the following requirements.</p> <table border="1" data-bbox="523 1346 1460 1523"> <tr> <td>Leakage current</td> <td>Value in4.3 shall be satisfied</td> </tr> <tr> <td>Capacitance Change</td> <td>Within $\pm 20\%$ of initial value.</td> </tr> <tr> <td>$\tan \delta$</td> <td>Not more than 200%of the specified value.</td> </tr> <tr> <td>Appearance</td> <td>There shall be no leakage of electrolyte.</td> </tr> </table> <p>Remark: If the capacitors are stored more than 1 year, the leakage current may increase. Please apply voltage through about 1 K Ω resistor, if necessary.</p>	Leakage current	Value in4.3 shall be satisfied	Capacitance Change	Within $\pm 20\%$ of initial value.	$\tan \delta$	Not more than 200%of the specified value.	Appearance	There shall be no leakage of electrolyte.
Leakage current	Value in4.3 shall be satisfied									
Capacitance Change	Within $\pm 20\%$ of initial value.									
$\tan \delta$	Not more than 200%of the specified value.									
Appearance	There shall be no leakage of electrolyte.									

<p>4.9</p>	<p>Surge test</p>	<p><Condition> Applied a surge voltage to the capacitor connected with a $(100 \pm 50)/CR$ (K Ω) resistor. The capacitor shall be submitted to 1000 cycles, each consisting of charge of 30 ± 5s, followed discharge of 5 min 30s. The test temperature shall be 15~35°C. CR :Nominal Capacitance (μ F) <Criteria></p> <table border="1" data-bbox="555 421 1422 595"> <tr> <td>Leakage current</td> <td>Not more than the specified value.</td> </tr> <tr> <td>Capacitance Change</td> <td>Within $\pm 15\%$ of initial value.</td> </tr> <tr> <td>tan δ</td> <td>Not more than the specified value.</td> </tr> <tr> <td>Appearance</td> <td>There shall be no leakage of electrolyte.</td> </tr> </table> <p>Attention: This test simulates over voltage at abnormal situation only. It is not applicable to such over voltage as often applied.</p>	Leakage current	Not more than the specified value.	Capacitance Change	Within $\pm 15\%$ of initial value.	tan δ	Not more than the specified value.	Appearance	There shall be no leakage of electrolyte.
Leakage current	Not more than the specified value.									
Capacitance Change	Within $\pm 15\%$ of initial value.									
tan δ	Not more than the specified value.									
Appearance	There shall be no leakage of electrolyte.									
<p>4.10</p>	<p>Solderability test</p>	<p><Condition> The capacitor shall be tested under the following conditions: Soldering temperature : $245 \pm 3^\circ\text{C}$ Dipping depth : 2mm Dipping speed : 25 ± 2.5mm/s Dipping time : 3 ± 0.5s <Criteria></p> <table border="1" data-bbox="541 1099 1398 1182"> <tr> <td>Coating quality</td> <td>A minimum of 95% of the surface being immersed</td> </tr> </table>	Coating quality	A minimum of 95% of the surface being immersed						
Coating quality	A minimum of 95% of the surface being immersed									

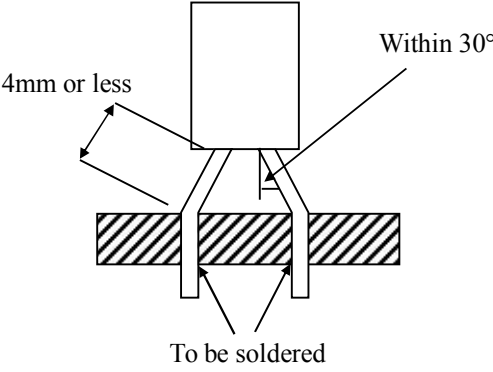
<p>4.11</p>	<p>Vibration test</p>	<p><Condition> The following conditions shall be applied for 2 hours in each 3 mutually perpendicular directions. Vibration frequency range : 10Hz ~ 55Hz Peak to peak amplitude : 1.5mm Sweep rate : 10Hz ~ 55Hz ~ 10Hz in about 1 minute</p> <p>Mounting method: The capacitor with diameter greater than 12.5mm or longer than 25mm must be fixed in place with a bracket.</p>  <p><Criteria> After the test, the following items shall be tested:</p> <table border="1" data-bbox="517 1025 1369 1249"> <tr> <td>Inner construction</td> <td>No intermittent contacts, open or short circuiting. No damage of tab terminals or electrodes.</td> </tr> <tr> <td>Appearance</td> <td>No mechanical damage in terminal. No leakage of electrolyte or swelling of the case. The markings shall be legible.</td> </tr> </table>	Inner construction	No intermittent contacts, open or short circuiting. No damage of tab terminals or electrodes.	Appearance	No mechanical damage in terminal. No leakage of electrolyte or swelling of the case. The markings shall be legible.				
Inner construction	No intermittent contacts, open or short circuiting. No damage of tab terminals or electrodes.									
Appearance	No mechanical damage in terminal. No leakage of electrolyte or swelling of the case. The markings shall be legible.									
<p>4.12</p>	<p>Resistance to solder heat test</p>	<p><Condition> Terminals of the capacitor shall be immersed into solder bath at $260 \pm 5^\circ\text{C}$ for 10 ± 1 seconds or $400 \pm 10^\circ\text{C}$ for 3_{-0}^{+1} seconds to 1.5~2.0mm from the body of capacitor.</p> <p>Then the capacitor shall be left under the normal temperature and normal humidity for 1~2 hours before measurement.</p> <p><Criteria></p> <table border="1" data-bbox="504 1659 1366 1843"> <tr> <td>Leakage current</td> <td>Not more than the specified value.</td> </tr> <tr> <td>Capacitance Change</td> <td>Within $\pm 10\%$ of initial value.</td> </tr> <tr> <td>$\tan \delta$</td> <td>Not more than the specified value.</td> </tr> <tr> <td>Appearance</td> <td>There shall be no leakage of electrolyte.</td> </tr> </table>	Leakage current	Not more than the specified value.	Capacitance Change	Within $\pm 10\%$ of initial value.	$\tan \delta$	Not more than the specified value.	Appearance	There shall be no leakage of electrolyte.
Leakage current	Not more than the specified value.									
Capacitance Change	Within $\pm 10\%$ of initial value.									
$\tan \delta$	Not more than the specified value.									
Appearance	There shall be no leakage of electrolyte.									

4.13	Change of temperature test	<p><Condition> Temperature cycle: According to IEC60384-4 No.4.7 methods, capacitor shall be placed in an oven, the condition according as below:</p> <table border="1" data-bbox="499 253 1342 472"> <thead> <tr> <th>Temperature</th> <th>Time</th> </tr> </thead> <tbody> <tr> <td>(1)+20°C</td> <td>≤3 Minutes</td> </tr> <tr> <td>(2) -25°C(-40°C)</td> <td>30±2 Minutes</td> </tr> <tr> <td>(3) +105°C</td> <td>30±2 Minutes</td> </tr> <tr> <td colspan="2">(1) to (3)=1 cycle, total 5 cycle</td> </tr> </tbody> </table> <p><Criteria> The characteristic shall meet the following requirement.</p> <table border="1" data-bbox="499 573 1364 703"> <tbody> <tr> <td>Leakage current</td> <td>Not more than the specified value.</td> </tr> <tr> <td>tan δ</td> <td>Not more than the specified value.</td> </tr> <tr> <td>Appearance</td> <td>There shall be no leakage of electrolyte.</td> </tr> </tbody> </table>	Temperature	Time	(1)+20°C	≤3 Minutes	(2) -25°C(-40°C)	30±2 Minutes	(3) +105°C	30±2 Minutes	(1) to (3)=1 cycle, total 5 cycle		Leakage current	Not more than the specified value.	tan δ	Not more than the specified value.	Appearance	There shall be no leakage of electrolyte.
Temperature	Time																	
(1)+20°C	≤3 Minutes																	
(2) -25°C(-40°C)	30±2 Minutes																	
(3) +105°C	30±2 Minutes																	
(1) to (3)=1 cycle, total 5 cycle																		
Leakage current	Not more than the specified value.																	
tan δ	Not more than the specified value.																	
Appearance	There shall be no leakage of electrolyte.																	
4.14	Damp heat test	<p><Condition> Humidity test: According to IEC60384-4 No.4.12 methods, capacitor shall be exposed for 500±8 hours in an atmosphere of 90~95%R H .at 40±2°C, the characteristic change shall meet the following requirement.</p> <p><Criteria></p> <table border="1" data-bbox="472 1099 1418 1272"> <tbody> <tr> <td>Leakage current</td> <td>Not more than the specified value.</td> </tr> <tr> <td>Capacitance Change</td> <td>Within ±20% of initial value.</td> </tr> <tr> <td>tan δ</td> <td>Not more than 120% of the specified value.</td> </tr> <tr> <td>Appearance</td> <td>There shall be no leakage of electrolyte.</td> </tr> </tbody> </table>	Leakage current	Not more than the specified value.	Capacitance Change	Within ±20% of initial value.	tan δ	Not more than 120% of the specified value.	Appearance	There shall be no leakage of electrolyte.								
Leakage current	Not more than the specified value.																	
Capacitance Change	Within ±20% of initial value.																	
tan δ	Not more than 120% of the specified value.																	
Appearance	There shall be no leakage of electrolyte.																	
4.15	Vent test	<p><Condition> The following test only apply to those products with vent products at diameter ≥Ø6.3 with vent. D.C. test The capacitor is connected with its polarity reversed to a DC power source. Then a current selected from Table 2 is applied.</p> <p><Table 2></p> <table border="1" data-bbox="499 1675 1002 1760"> <thead> <tr> <th>Diameter (mm)</th> <th>DC Current (A)</th> </tr> </thead> <tbody> <tr> <td>22.4 or less</td> <td>1</td> </tr> </tbody> </table> <p><Criteria> The vent shall operate with no dangerous conditions such as flames or dispersion of pieces of the capacitor and/or case.</p>	Diameter (mm)	DC Current (A)	22.4 or less	1												
Diameter (mm)	DC Current (A)																	
22.4 or less	1																	

5、体积和最大纹波电流 CASE SIZE & MAX RIPPLE CURRENT

Size $\Phi D \times L$ (mm) , Maximum Permissible Ripple Current at 105°C, 120 Hz

μF	WV	6.3		10		16	
	ITEM	D×L	R.C.	D×L	R.C.	D×L	R.C.
10						5×11	36
22				5×11	48	5×11	53
33		5×11	54	5×11	58	5×11	65
47		5×11	65	5×11	70	5×11	80
100		5×11	95	5×11	105	5×11	125
						6.3×11	142
120						6.3×11	155
220		5×11	153	6.3×11	166	6.3×11	213
330		6.3×11	216	6.3×11	239	8×12	315
470		6.3×11	258	6.3×11	285	8×12	366
680		6.3×11	300				
1000		8×9	380	10×12.5	571	10×16	680
		8×12	443				
2200		10×16	740	10×20	886	10×20	1000
						13×20	1108
3300		10×20	1032	13×20	1205	13×25	1389
4700		13×20	1280	13×25	1492	16×25	1740
10000		16×25	1897	16×30	1980	16×35	2379

μF	WV	25		35		50	
	ITEM	D×L	R.C.	D×L	R.C.	D×L	R.C.
2.2						5×11	20
3.3						5×11	30
4.7		5×11	25	5×11	28	5×11	37
10		5×11	38	5×11	40	5×11	54
22		5×11	57	5×11	67	5×11	79
33		5×11	75	5×11	80	5×11	101
47		5×11	84	5×11	101	6.3×11	133
100		6.3×11	159	6.3×11	168	8×12	229
			8×12	200	8×12		
220		8×12	195	8×12	294	10×12.5	450
			285				
330		8×12	340	10×12.5	419	10×16	589
470		10×12.5	406	8×20	532	10×20	707
			471	10×16	547		
1000		10×20	821	10×20	820	16×25	1478
				13×20	1023		
2200		13(12.5)×20	1176	16×25	1497	16×30	1759
		13×25	1290	18×20	1550	16×35	1884
3300		13×25	1200	16×30	1808	18×35	2167
		16×25	1646				
4700		16×25	1750	18×35	2335		
		16×30	2012				
6800		16×35	2308	18×40	2400		

μF	WV	63		100	
	ITEM	D×L	R.C.	D×L	R.C.
1				5×11	16
2.2				5×11	23
3.3				5×11	29
4.7	5×11		40	5×11	40
10	5×11		59	6.3×11	61
22	5×11		79	6.3×11	92
33	6.3×11		122	8×12	144
47	6.3×11		146	10×12.5	199
100	8×12		170	10×20	349
	10×12.5		251		
220	10×16		400	13×25	662
	10×20		504		
330	13×20		688	13×25	800
470	13×20		810	16×25	990
1000	16×25		1448	18×40	2020
2200	18×35		1781		
4700	22×40		2520		

μF	WV	160		200		250	
	ITEM	D×L	R.C.	D×L	R.C.	D×L	R.C.
1						6.3×11	17
2.2						6.3×11	27
3.3				6.3×11	30	6.3×11	35
4.7	6.3×11	41		6.3×11	40	6.3×11	40
				8×12	45	8×12	45
10	8×12		60	10×12.5	72	10×12.5	75
22	10×16	110		10×16	113	10×16	112
						10×20	130
33	10×20		156	10×20	165	13×20	184
47	10×20		195	10×20	194	13×25	238
100	13×25		360	16×25	386	16×30	422
220	16×30		680	18×25	635	18×35	485
330	18×35		830	18×35	864		
390	18×35		850	18×35	904		
470	18×40		880	18×40	1016		
560	18×45		925	18×45	1112		

μF	WV	350		400		450	
	ITE M	D×L	R.C.	D×L	R.C.	D×L	R.C.
0.47		6.3×11	8	6.3x11	8		
1		6.3×11	18	6.3×11	19	6.3×11	16
2.2		6.3x11	25	6.3x11	25	8x12	24
2.2		8×12	30	8×12	30	10×12.5	30
3.3		8×12	40	8×12	35	8×12	29
4.7		8×12	43	8×9	35	8x12	32
				8×12	40		
				10×12.5	46		
6.8				10x12.5	52		
10		10×16	73	10×12.5	70	13×20	84
15				10x12.5	70		
				10x16	82		
22		13×20	150	13×16	135	13×25	131
				13×25	163		
33		16×25	200	13x20	175	16x20	215
				16x19	195		
				13×25	193		
47		16×25	265	13×25	245	16x25	281
				16×20	256		
				16x25	305		
56		16x30	280	13x30	313	16x30	352
68		16x30	288	16x30	396	16x30	342
82		18x30	372	18x25	409	18x30	440
100		18×35	460	18×25	452	18×35	490
120				18x30	532	18x40	592
150				18x35	580	18x45	640
180				18x40	616		

Remark:

- 1) Specification are subject to change without notice should a safety or technical concern arise regarding the product ,please be sure to contact our sales offices ;
- 2) The sizes in the above table are all general specifications. If you need other specifications, please contact us.

6.外型图

DIMENSIONS

Unit: mm

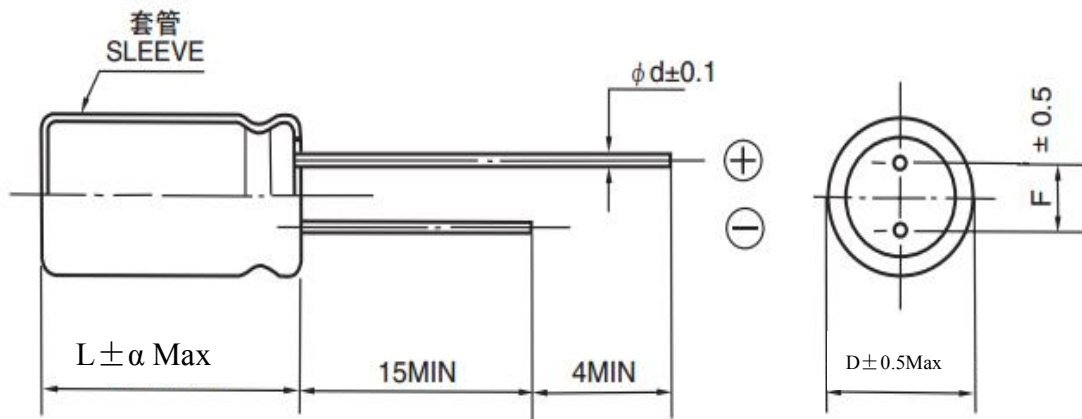

ϕD	5.0	6.3	8.0	10.0	13.0	16.0	18.0	22
F	2.0	2.5	2.5/3.5	5.0		7.5		10
ϕd	0.5			0.6		0.8		1.0
α	(L < 20) 1.5 (L ≥ 20) 2.0							

7.纹波电流修正系数

MULTIPLIER FOR RIPPLE CURRENT

频率系数 Frequency coefficient

coefficient Cap(μF)	Frequency (Hz)	60 (50)	120	500	1K	≥10K
	0.1~47μF		0.80	1.00	1.20	1.30
100~1000μF		0.80	1.00	1.10	1.15	1.20
2200~4700μF		0.80	1.00	1.05	1.10	1.15

8. Forming Dimension

Unit: mm

Cutting Type

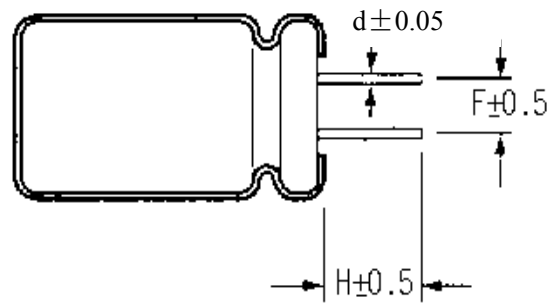

Shape Code	ϕD	$\phi 5$	$\phi 6.3$	$\phi 8$	$\phi 10 \sim \phi 13$	$\phi 16 \sim \phi 18$
Cutting-3.5mm	F	2.0	2.5	3.5	5.0	7.5
	H	3.5	3.5	3.5	3.5	3.5
	d	0.5	0.5	0.5	0.6	0.8
Shape Code	ϕD	$\phi 5$	$\phi 6.3$	$\phi 8$	$\phi 10 \sim \phi 13$	$\phi 16 \sim \phi 18$
Cutting-5.5mm	F	2.0	2.5	3.5	5.0	7.5
	H	5.5	5.5	5.5	5.5	5.5
	d	0.5	0.5	0.5	0.6	0.8

Shape Code	ϕD	$\phi 5$	$\phi 6.3$	$\phi 8$	$\phi 10 \sim \phi 13$	$\phi 16 \sim \phi 18$
Cutting-6.0mm	F	2.0	2.5	3.5	5.0	7.5
	H	6.0	6.0	6.0	6.0	6.0
	d	0.5	0.5	0.5	0.6	0.8

Shape Code	ϕD	$\phi 5$	$\phi 6.3$	$\phi 8$	$\phi 10 \sim \phi 13$	$\phi 16 \sim \phi 18$
Cutting-7.0mm	F	2.0	2.5	3.5	5.0	7.5
	H	7.0	7.0	7.0	7.0	7.0
	d	0.5	0.5	0.5	0.6	0.8

9. Taping Dimension:

9.1 Straight foot braid:

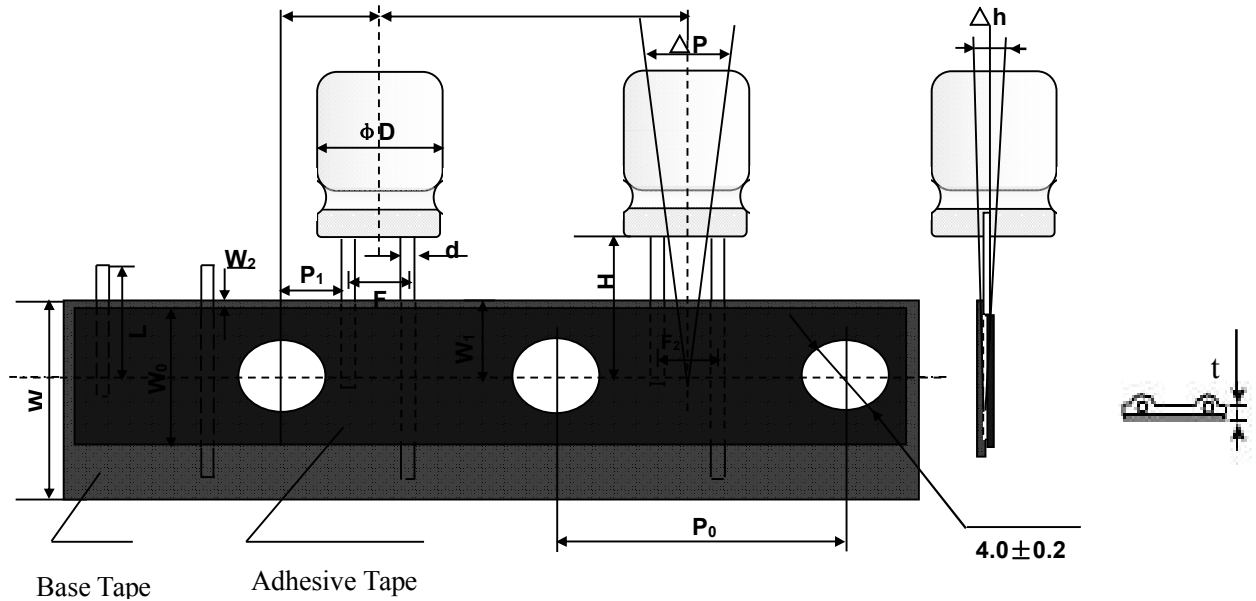

Taping dimension

Unit: mm

Item	Code	Code							
		T2	TB	T3	T5		T7		
Diameter	D	5	6.3、8	8	10	13	16	18	
Height	A	5~30							
Lead Diameter	$d \pm 0.05$	0.5	0.5	0.5	0.6		0.8		
Component Spacing	$P \pm 1.0$	12.7							
Pitch of sprocket holes	$P_0 \pm 0.2$	12.7							
Distance between centers of terminal and the sprocket holes	$P_1 \pm 0.5$	5.35	5.10	4.60	3.85	5.00	3.75	3.75	
Feed hole center to component center	$P_2 \pm 1.0$	6.35	6.35	6.35	6.35	7.50	7.50	7.50	
Distance between centers of component leads	$F + 0.5 - 0.5$	2.0	2.5	3.5	5.0		7.5		
Distance between centers of component leads Adhesive Tape cover	$F_2 + 0.8 - 0.5$	2.0	2.5	3.5	5.0		7.5		
Carrier tape width	$W + 1 - 0.5$	18							
Hold down tape width	W_0	7min							
Distance between the center of upper edge of carrier tape and sprocket hole	$W_1 \pm 0.5$	9							
Distance between the upper edges of the carrier tape and the hold down tape	W_2	3max							
Distance between the abscissa and the bottom of the components body	$H \begin{matrix} +0.75 \\ -0.5 \end{matrix}$	18.5							
Cut off position of defectives	L	11 max							
Max. lateral deviation of the component body vertical to the tape plane	Δh	2 max							
Max. deviation of the component body in the tape plane	ΔP	1.3 max							

9.2 Enlarge the foot braid:

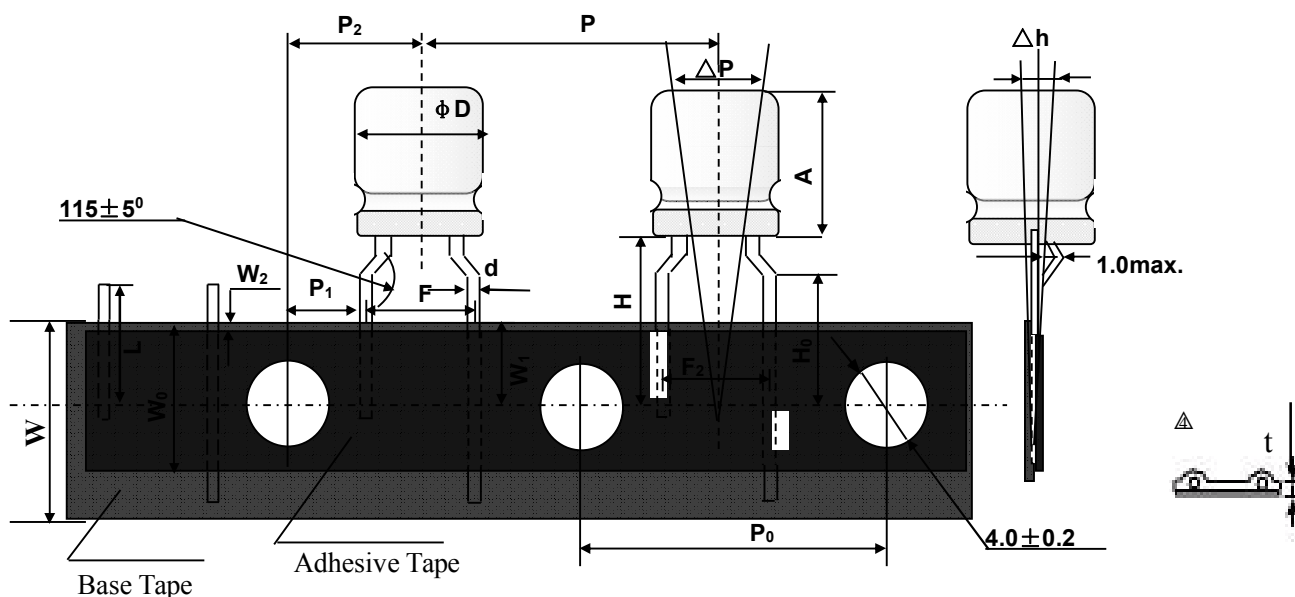

Taping dimension

Unit: mm

Item		Code	T5	T5	T5
Diameter	D		5	6.3	8
Height	A		9~20		
Lead Diameter	$d \pm 0.05$		0.5	0.5	0.5
Component Spacing	$P \pm 1.0$		12.7		
Pitch of sprocket holes	$P_0 \pm 0.2$		12.7		
Distance between centers of terminal and the sprocket holes	$P_1 \pm 0.5$		3.85	3.85	3.85
Feed hole center to component center	$P_2 \pm 1.0$		6.35	6.35	6.35
Distance between centers of component leads	$F + 0.5 - 0.5$		5.0	5.0	5.0
Distance between centers of component leads Adhesive Tape cover	$F_2 + 0.8 - 0.5$		5.0	5.0	5.0
Carrier tape width	$W + 1 - 0.5$		18		
Hold down tape width	W_0		7min		
Distance between the center of upper edge of carrier tape and sprocket hole	$W_1 \pm 0.5$		9		
Distance between the upper edges of the carrier tape and the hold down tape	W_2		3max		
Distance between the abscissa and the bottom of the components body	$H + 0.75 - 0.5$		18.5		
Distance between the abscissa and the reference plane of the components with crimped leads	$H_0 \pm 0.5$		16.0		
Cut off position of defectives	L		11 max		
Max. lateral deviation of the component body vertical to the tape plane	Δh		2 max		
Max. deviation of the component body in the tape plane	ΔP		1.3 max		

1. 电路设计

(1) 在确认使用和安装环境时，作为按产品样本设计说明书上所规定的额定性能范围内使用的电容器，应避免在下述情况下使用：

- a) 高温（温度超过最高使用温度）
- b) 过流（电流超过额定纹波电流）
- c) 过压（电压超过额定电压）
- d) 施加反向电压或交流电压
- e) 使用于反复多次充电和放大的电路中。

另：1) 在电路设计时，请选用与机器寿命相当的电容器。

2) 机器性能有特殊要求时，可与研发人员探讨，制作适用的特殊电容器。

- (2) 电容器外壳，辅助引出端子与正，负极以及电路板间必须完全隔离；
- (3) 当电容器套管的绝缘不能保证时，在有绝缘性能特定要求的地方请不要使用；
- (4) 请不要在下述环境下使用电容器：
 - a) 直接与水，盐水及油类相接触或结露的环境；
 - b) 充满有害气体的环境（硫化物， H_2SO_3 , HNO_3 , Cl_2 氨水等）；
 - c) 置于日照， O_3 , 紫外线及有放射性物质的环境；
 - d) 振动及冲击条件超过了样本及说明书的规定范围的恶劣环境；
- (5) 在设计电容器的安装时，必须确认下述内容：
 - a) 电容器正负极间距必须与线路板孔距相吻合；
 - b) 保证电容器防爆阀上方留有一定的空间；
 - c) 电容器防爆阀上方尽量避免设计，安装其他元件；
 - d) 电路板上，电容器的安装位置，请不要有其他配线；
 - e) 电容器四周及电路板上尽量避免设计，安装发热元件。
- (6) 另外，在设计电路时，必须确认以下内容：
 - a) 温度及频率的变化不至于引起电性能变化；
 - b) 双面印刷板上安装电容器时，电容器的安装位置避免多余的基板孔和过孔；
 - c) 两只以上电容器串聊连接时的电压均衡。

2. 元件安装

(1) 安装时，请遵守以下内容：

- a) 为了对电容器进行点检，测定电器性能时，除了卸下的电容器，装入机器中通过电的电容器请不要使用；
 - b) 当电容器产生再生电压时，需通过约 $1K\Omega$ 左右的电阻进行放电；
 - c) 长期保存的电容器，需通过约 $1K\Omega$ 左右的电阻加压处理；
 - d) 确认规格（静电容量及额定电压等）及极性后，再安装；
 - e) 不要让电容器掉到地上，掉下的电容器请不要使用；
 - f) 变形的电容器不要安装；
 - g) 电容器正负极间距与电路板孔必须相吻合；
 - h) 自动插入机的机械手力量不宜过大；
- (2) 焊接式，请确认下面内容
- a) 注意不要将焊锡附着在端子以外；
 - b) 焊接条件（温度，时间，次数）必须按规定说明执行；
 - c) 不要将电容器本身浸入到焊锡溶液中；
 - d) 焊接时，不要让其他产品倒下碰到电容器上；
- (3) 焊接后的处理应不产生以下的机械应力

- a) 电容器发生倾倒，扭转；
 - b) 电容器碰到其他线路板；
 - c) 使其他物体碰撞到电容器。
- (4) 电容器不要用洗净剂洗净，不过，在有必要洗净的情况下对电容进行洗净，必须在产品规格书规定的范围内进行。
- (5) 对有必要洗净的电容器，洗净时，需确认下列内容：
- a) 洗净剂污染管理（电导率，PH 值，比重，水分等）
 - b) 洗净后，不能保管在洗净液环境中及密闭容器中，要采用（最高使用温度以下的）热风干燥印刷电路板及电容器，使之不残留洗净液成分。
- (6) 不使用含卤素的固定剂，树脂涂层剂
- (7) 使用固定剂，涂层剂时，请确认以下内容
- a) 电路板与电容器之间，不能残留焊接残渣及污垢；
 - b) 固定剂，涂层剂吸附前，尽可能不残留洗净成分，进行干燥处理，使印刷孔不堵塞；
 - c) 固定剂，涂层剂硬化条件，按规定说明书要求执行。

3. 组装使用

- (1) 组装使用中，请遵守以下内容：电容器的端子间不要直接接触，另外，不要让导体物质引起正负极短路。
- (2) 请确认所安装电容器所处环境
- a) 不要与水或油污接触或处于结露状态；
 - b) 不要让日光，O3,紫外线及放射直接照射到电容器上；
 - c) 不要处于充满有害气体的环境（硫化氢，亚硫酸，亚硝酸，氨水，CL2，等）
 - d) 震动及冲击不要超样本或规格说明中规定值。

4. 保守点检

工厂企业用的电容器，必须定期点检，定期点检项目包括外观检查及电性能的测试。

5. 意外情况

- (1) 组装使用过程中，如电容器防爆阀打开，请切断组装主电源或拔下电源线插头。
- (2) 电容器防爆阀动作时，因有超过 100℃ 高温气体喷出，脸不要接近，出的气体进入眼睛时，立即用水清洗眼睛，不要当电容器电解液，电解液溅到皮肤上时，用肥皂清洗。

6. 熏蒸处理

当组装电容器的电子产品出口到海外时，用溴化钾等卤化物节能型熏蒸处理，因采用此方法可能会产生因卤素离子而引起的腐蚀反应，请务必小心，熏蒸时，熏蒸液不能直接接触电子产品，同时有必要进行充分干燥处理，估计有熏蒸液附着及干燥不充分时，有必要先查询一下安全性。

7. 储存条件

- (1) 在温度为 5-30℃，湿度为 75% 以下的室内储存；
- (2) 不要保存在组装使用中禁用的环境及同等条件下。
- (3) 经过一年后，电容器应用额定电压，加上串联电阻 1000Ω，30 分钟来重老化处理。

8. 报废情况

废弃的电容器，可任选下面一种方法进行处理：

- (1) 电容器上开孔压碎后焚烧；
- (2) 电容器不焚烧时，交给专业废品回收人员进行深埋等处理。

When using Aluminum Electrolytic Capacitors, please pay attention to the points listed below.

If the following types of electrical loads are applied to Aluminum Electrolytic Capacitors, rapid

deterioration of electrical property occurs:

- ◆ Reverse voltage
- ◆ Overvoltage exceeding rated working voltage
- ◆ Current exceeding rated ripple current
- ◆ Severe charging/discharging

At such times,severe heat is generated,gas is emitted,then electrolyte leaks from the sealed area,and pressure relief vent operates due to increase of internal pressure.In the worst case,explosion or igniton may occur,and along with destruction of the capacitor combustibles may burst out.

1.CAUTION DURING CIRCUIT DESIGN

1)OPERATIONAL ENCIRONMENT,MOUNTING ENVIRONMENT AND CONDITIONS

Ensure that operational and mounting conditions follow the specified conditions detailed in the catalog and specification sheets

2)OPERATING TEMPERARURE,RIPPLE CURRENT AND LOAD LIFE.

Operating temperature and applied ripple current should be within the specified value in the catalog or specification sheets.

Do not use Aluminum Electrolytic Capacitors at temperature which exceeds the specified category temperatures range.

Do not apply excessive current to the capacitors,which exceeds the specified rated ripple current.

During circuit design ,please ensure that capacitors are selected to match with the lifetime requirements of the application

3).APPLICATION

Aluminum Electrolytic Capacitors are normally polarized .Reverse voltage or AC coltage should not be applied.When polarity may flip over,non-polar type should be used,but the non-polar type cannot be used for AC.

Standard Aluminum E lectrolytic Capacitors are not suitable for rapid charge and discharge applications.Please consult with Shanghai Suzuki Electronics or sales office of Suzuki Techno Group in your area about special designed capacitors for rapid charge and discharge.

4)APPLIED COLTAGE

Do not exceed the rated voltage of capacitors

5)INSULATION

Aluminum Electrolytic Capacitors should be electricially isolated from the following.

Aluminum case,cathode lead wire,anode lead wire and circuit pattern;

Auxiliary termianls of snap-in type,anode terminal,outward terminals and circuit pattern.

The PVC sleeve of Aluminum Electrolytic Capacitors is not recognized as an insulator,and therefore ,the standard capacitor should not be used in a place where insulation function is needed.

Please consult with Shanghai Suzuki Electronics or sales office of Suzuki Techno Group in your area,if you require a higher grade of insulating sleeve.

6)CONDITIONS OF USE

The following environments should be avoided when suing Aluminum Electrolytic Capacitors.

Damp conditions such as water ,salt water or oil spray or fumes,high humidity or humidity condensation situations;.

Hazardous gas/fumes such as hydrogen sulfide,sulfurous acid gas,nitrous acid,chlorine gas,ammonia or bromine gas;

Exposure of ozone ,ultraviolet rays or radiation;

Severe vibration or shock which exceeds the cinditon specified in the catalog or specification sheets.

7) CONSIDERATION TO ASSEMBLY CONDITION

In designing a circuit, the following matters should be ensured in advance to the capacitor's assembly on the printed circuit board (PC board)

Design the appropriate hole spacing to match the lead pitch of capacitors;

Do not locate any wiring and circuit patterns directly above the capacitor's vent;

Ensure enough free space above the capacitor's vent. The recommended space is specified in the catalog or specification sheets;

In case the capacitor's vent is facing the PC board, make a gas release hole on PC board.

The sealing side of the screw terminal type should not face down in the application. When the capacitors are mounted horizontally, the anode screw terminals must be positioned at upper side.

8) CONSIDERATION TO CIRCUIT DESIGN

Any copper lines or circuit patterns should not be laid under the capacitor;

Parts which radiate heat should not be placed close to the reverse side of the Aluminum Electrolytic Capacitors on the PC board.

9) OTHERS

Performance of electrical characteristics of Aluminum Electrolytic Capacitors is affected by variation of operating temperature and frequency. Consider this variation when designing the circuit.

Excessive holes and connection hole between both sides on the PC board should be avoided around or under the mounting area of the Aluminum Electrolytic Capacitors on double sided or multilayer PC board.

Torque of tightening screw terminals should not exceed the specified maximum value which is described in the catalog and specification sheets.

Consider current balance when 2 or more Aluminum Electrolytic Capacitors are connected in parallel.

Use bleeder resistors when 2 or more Aluminum Electrolytic Capacitors are connected in series. In this case, the resistors should be connected parallel to the capacitors.

1. CAUTION FOR ASSEMBLING CAPACITORS

1) CAUTION BEFORE ASSEMBLY

Aluminum Electrolytic Capacitors cannot be recycled after mounting and applying electricity in unit. The capacitors, which are removed from PC board for the purpose of measuring electrical characteristics at the periodical inspection, should only be recycled for the same position.

Aluminum Electrolytic Capacitors may accumulate charge naturally during storage. In this case, discharge through a 1KOHM resistor before use;

Leakage current of Aluminum Electrolytic Capacitors may be increased during long storage time. In this case, the capacitors should be subject to voltage treatment through a 1KOHM resistor before use.

2) IN THE ASSEMBLY PROCESS-1

Ensure rated voltage and capacitance of the capacitors before mounting;

Ensure capacitors polarity before mounting;

Do not use a capacitor which has been dropped onto a hard surface;

Do not use a capacitor with damaged or dented case or seals.

3) IN THE ASSEMBLY PROCESS-2

Capacitors should be mounted after confirmation that hole spacing on PC board matches the lead pitch of the capacitors;

The snap-in type of capacitors should be mounted firmly on the PC board without a gap between the capacitor body and the surface of PC board;

Avoid excessive force when clinching lead wire during auto-insertion process;

Avoid excessive shock to capacitors by automatic inserting machine, during mounting, parts inspection or centering operations;

Please utilize supporting material such as strap of adhesive to mount capacitors to PC board when it is anticipated that vibration or shock is applied.

4) SOLDERING

Soldering conditions (temperature, time) should be within the specified conditions which are described in the catalog or specification sheets;

In case lead wire reforming is needed due to inappropriate pitch between capacitor and holes on PC board, stress to the capacitor should be avoided;

In case of maintenance by soldering iron, if it is required to detach the capacitor, it should be removed from PC board after solder has melted sufficiently in order to reduce stress on the lead wires/terminals of the capacitor;

Soldering iron should never touch the capacitor's body.

5) FLOW SOLDERING

Do not dip capacitor's body into melted solder, It should only be soldered on the reverse side of the PC board on which the capacitors are mounted;

Soldering condition ((preheat, soldering temperature, dipping time) should be within the specified standard which is described in the catalog or specification sheets;

Flux should not be adhered to capacitor's body but only to its terminals;

Other devices which are mounted close to capacitors should not touch the capacitors.

6) REFLOW SOLDERING

Reflow soldering conditions (preheat, soldering, temperature, reflow time) should follow the specified standard which is described in the catalog or specification sheets;

Heating standard should depend on surface of the capacitor color or materials when infrared rays are used because the capacitor's heat absorption depends on the surface color or materials. Check heat condition;

Standard Aluminum Electrolytic Capacitors cannot withstand two or more reflow processes.

7) HANDLING AFTER SOLDERING

Do not bend or twist the capacitor's body after soldering on PC board;

Do not pick-up or move PC board by holding the soldered capacitors;

Do not hit the capacitors and isolate capacitors from the PC board or other device when stacking PC boards in store.

8) PC BOARD CLEANING

Standard Aluminum Electrolytic Capacitors should be free from halogenated solvents during PC board cleaning after soldering.

9) ADHESIVES AND COATING MATERIALS

Do not use halogenated adhesives and coating materials to fix Aluminum Electrolytic Capacitors;

Flux between the surface of the PC board and sealing of capacitors should be cleaned before using adhesives or coating materials;

Solvents should be dried up before using adhesives or coating materials;

Do not cover up all the sealing area of capacitors with adhesives or coating materials, make coverage

only partial.

2. CAUTION DURING USE OF CAPACITORS IN SETS

- 2.1 Do not touch the terminals of capacitors;
- 2.2 Do not connect electrical terminals of the capacitors. Keep the capacitors free from conductive solution, such as acid, alkali and so on;
- 2.3 Ensure the operational environment of the equipment in which the capacitor has been built is within the specified condition mentioned in the catalog or specification sheets.

3. MAINTENANCE

- 3.1 Periodical inspection should be carried out for the capacitors, which are used with industrial equipment; Check the following points at the inspection.
- 3.2 Visual inspection to check pressure relief vent open or leakage of electrolyte;
- 3.3 Electrical characteristics: leakage current, capacitance, dissipation factor and the other points which are mentioned in the catalog or specification sheets.

4. EMERGENCY ACTION

- 4.1 If the pressure relief vent is open and some gas blows out from the capacitor, turn the main switch of the equipment off or pull out the plug from the power outlet immediately;
- 4.2 During pressure relief vent operation, extremely hot gas (over 100°C) may blow out from the vent area of the capacitors. So keep your face and skin away from capacitors during its operation. In case of eye contact, flush the open eye(s) with large amount of clean water immediately. In case of ingestion, gargle with water immediately, and do not swallow. Also do not touch electrolyte but wash skin with soap and water in case of skin contact.

5. STORAGE CONDITION

- 5.1 Aluminum Electrolytic Capacitors should not be stored in high temperature or in high humidity. The suitable storage condition is 5°C-35°C, and less than 75% in relative humidity;
- 5.2 Aluminum Electrolytic Capacitors should not be stored in damp conditions such as water, salt water spray or oil spray;
- 5.3 Do not store Aluminum Electrolytic Capacitors in an environment full of hazardous gas (hydrogen sulfide gas, sulfurous acid gas, nitrous acid, chlorine gas, ammonia or bromine gas);
- 5.4 Aluminum Electrolytic Capacitors should not be stored under exposure to ozone, ultraviolet rays or radiation.
- 5.5 After one year, a capacitor should be reconditioned by applying rated voltage in series with a 1000Ω current limiting resistor for a time period of 30 minutes.

6. DISPOSAL

- 1) Please take either of the following actions in case of disposal.
Incineration (high temperature of more than 800°C) after crushing the capacitor's body;
Consignment to specialists of industrial waste.