

| | | | | | | |
|--------------------------------|--------|----------------------|--------------------|------------------|---|----------|
| 客戶名稱 CUSTOMER | | 客戶品名 CUSTOMER P/N | | 版本 REV. | A | |
| 產品類型 PRODUCT TYPE | 貼片共模電感 | 愛倫品名 Aillen P/N | ALMPRI-5020-SERIES | 文件編號 FILE NO. | | |
| 一. 外觀圖/DIMENSION (單位/UNIT: mm) | | | | | A | 4.8 ±0.2 |
| | | | | | B | 5.0 ±0.2 |
| | | | | | C | 2.5 Max |
| | | | | | D | 0.8 Typ |
| | | | | | E | 1.0 Typ |
| | | | | | F | 2.3 Ref |
| | | | | | G | 1.6 Ref |
| | | | | | H | 0.8 Ref |
| | | | | | I | 1.0 Ref |

二. 電路圖/CIRCUIT DIAGRAM

三. 注意事項/NOTE:

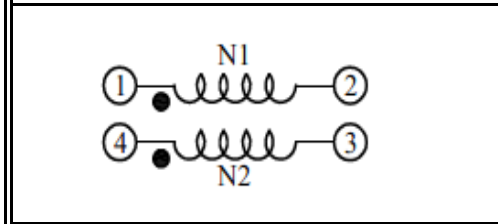

四. 電氣特性/ELECTRICAL CHARACTERISTIC

| Aillen P/N | Common mode Impedance (Ω) | Test Frequency | Rated Voltage (V) MAX | DCR (mΩ) MAX | Rated Current (A) Max. | IR (MΩ) MIN |
|-----------------|---------------------------|----------------|-----------------------|--------------|------------------------|-------------|
| ALMPRI-5020-101 | 100 (Typ) | 100MHz/0.5V | 50 | 13 | 6.0 | 10 |
| ALMPRI-5020-251 | 250 (Typ) | 100MHz/0.5V | 50 | 20 | 5.0 | 10 |
| ALMPRI-5020-501 | 500 (Typ) | 100MHz/0.5V | 50 | 27 | 4.0 | 10 |
| ALMPRI-5020-102 | 1000 (Typ) | 100MHz/0.5V | 50 | 34 | 2.0 | 10 |
| ALMPRI-5020-142 | 1400 (Typ) | 100MHz/0.5V | 50 | 56 | 1.5 | 10 |
| ALMPRI-5020-152 | 1500 (Typ) | 100MHz/0.5V | 50 | 56 | 1.5 | 10 |

注明：
 1. IDC: ΔT=40℃Typ.
 2. I. R: 50V(DC)/0.5S, 串联测试.

| | | | | | |
|----------------------|--------|----------------------|--------------------|------------------|---|
| 客戶名稱 CUSTOMER | | 客戶品名 CUSTOMER P/N | | 版本 REV. | A |
| 產品類型 PRODUCT TYPE | 貼片共模電感 | 愛倫品名 Aillen P/N | ALMPRI-5020-SERIES | 文件編號 FILE NO. | |

七. 特性曲線/CHARACTERISTICS(REFERENCE)

ALMPRI-5020-251

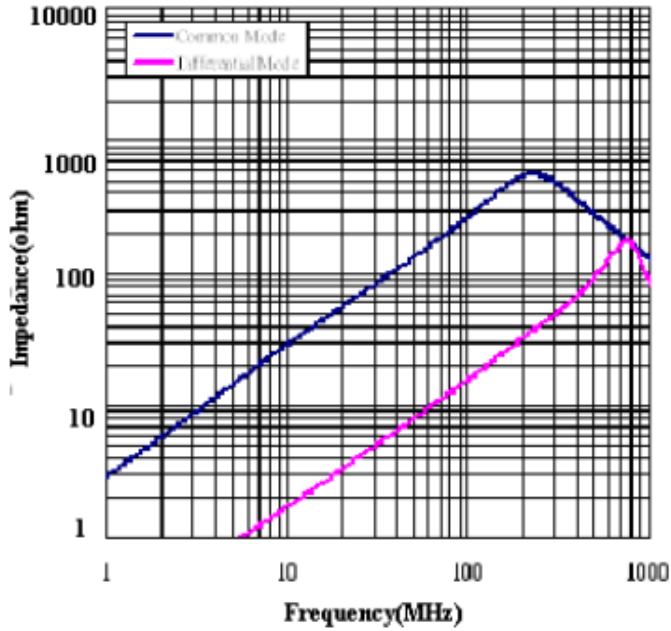

ALMPRI-5020-501

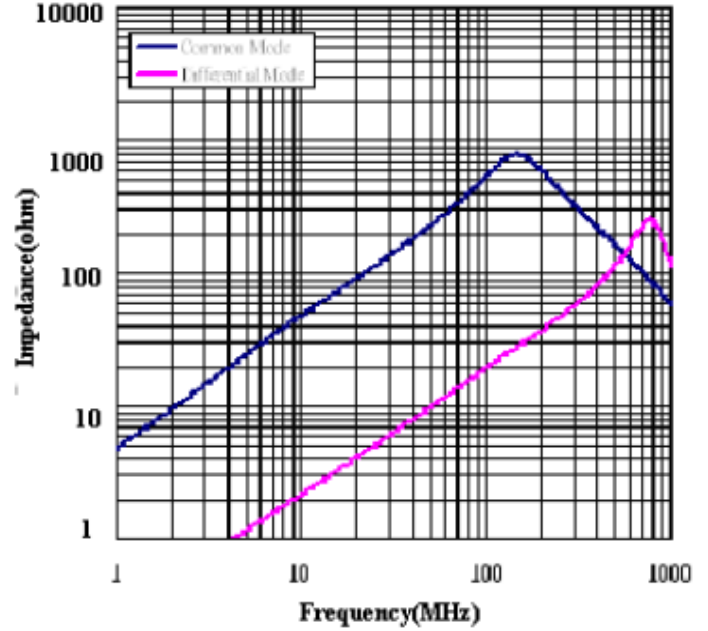

ALMPRI-5020-102

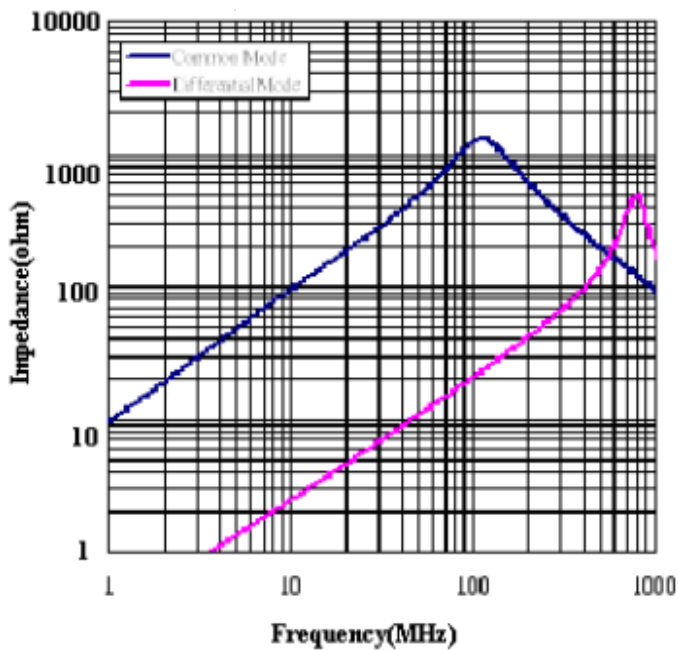

ALMPRI-5020-152

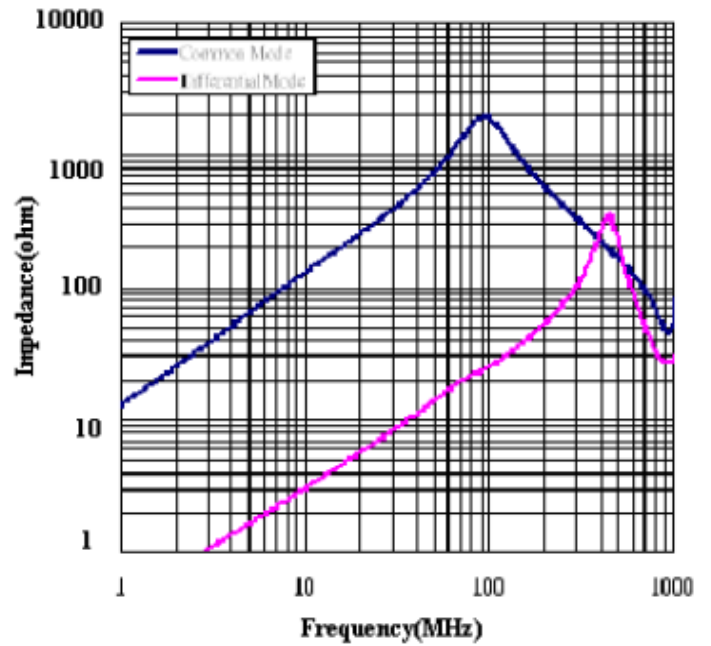

| | | | | | |
|----------------------|--------|----------------------|--------------------|------------------|---|
| 客戶名稱 CUSTOMER | | 客戶品名 CUSTOMER P/N | | 版本 REV. | A |
| 產品類型 PRODUCT TYPE | 貼片共模電感 | 愛倫品名 Aillen P/N | ALMPRI-5020-SERIES | 文件編號 FILE NO. | |

五. 材料清單/MATERIAL LIST

| NO. | ITEM | DESCRIPTION | SUPPLIER |
|-----|----------|--------------|-------------------|
| 1 | CORE | FERRITE | FENGYIN OR EQ |
| 2 | WIRE | P180 Grd1 | ELEKTRISOLA OR EQ |
| 3 | ADHESIVE | EPOXY RESIN | NAGASE OR EQ |
| 4 | SOLDER | Sn99.3:Cu0.7 | SHENMAO OR EQ |
| 5 | | | |

六. 編帶規格/TAPING SPECIFICATIONS

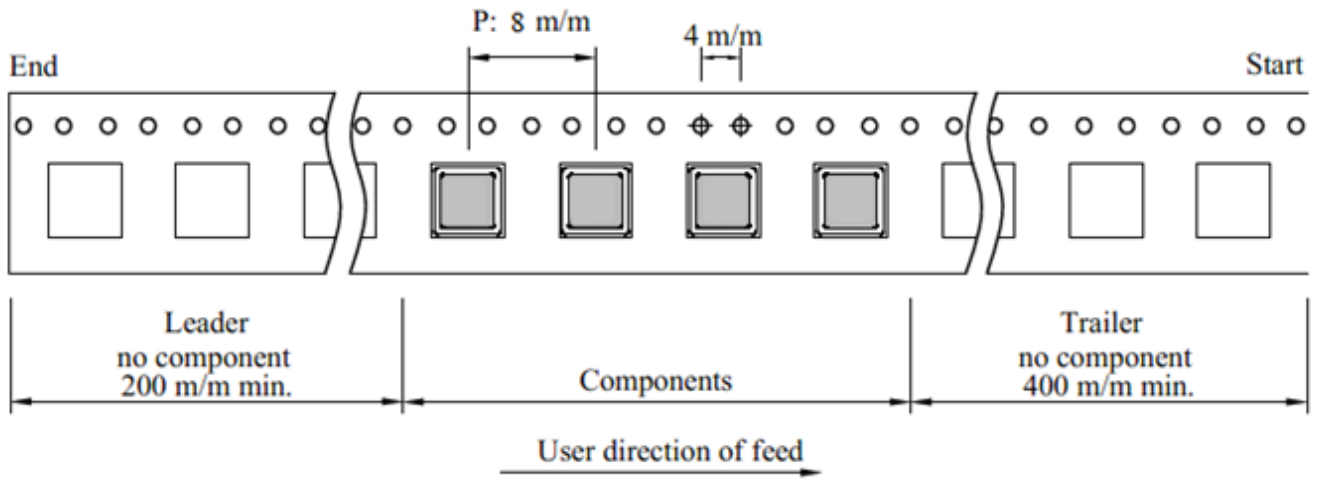

Adhesive strength of cover tape is 20 to 120 gf
The conduction band direction

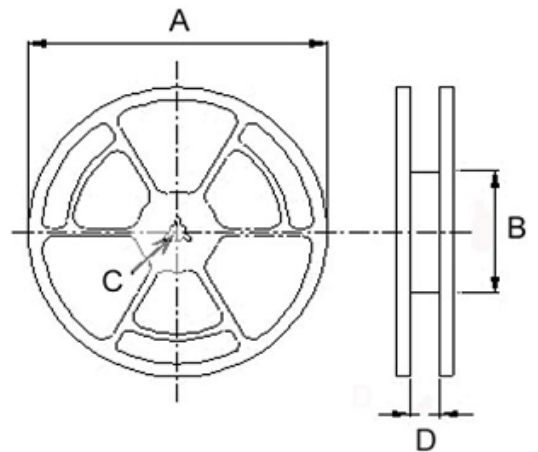
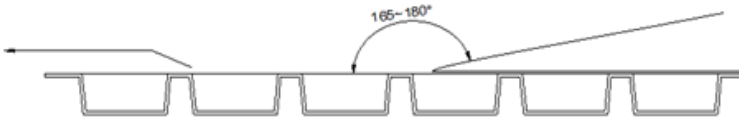

| Reel Dimensions (Unit: mm) | | | | Quantity |
|----------------------------|-----|----|------|----------|
| A | B | C | D | Pcs/Reel |
| 330 | 100 | 13 | 12.5 | 2500 |

| | | | | | |
|----------------------|--------|----------------------|--------------------|------------------|---|
| 客戶名稱 CUSTOMER | | 客戶品名 CUSTOMER P/N | | 版本 REV. | A |
| 產品類型 PRODUCT TYPE | 貼片共模電感 | 愛倫品名 Aillen P/N | ALMPRI-5020-SERIES | 文件編號 FILE NO. | |

七. 可靠性测试/RELIABILITY TESTING

| | |
|------------------------------------|--|
| Operating Temperature | - 40 to +125 °C (Contain Heating coil) |
| Appearance Inspection | No external defects by visual inspection |
| Terminal Strength | After soldering , between copper plaet and terminals of coils , push in two directions of X , Y with standing 10N(1.02kg) for10+/-2 sec. Terminal should not peel off. (Refer to figure at right) |
| Heat endurance of reflow soldering | Refer to figure |
| Insulating resistance | Over 100 MΩ at 100V D.C . between wire and core |
| Dielectric Strength | Apply at 0.5KV 3mA for 1 minute between wire and core |
| Temperature characteristics | Inductance coefficient (0~2,000) × 10 / °C (- 40~ + 125 °C) |
| Humidity characteristics | Inductance deviation within ± 10% , after 96 hours in 90~95% relative humidity at 40 ± 2 °C and 1 hours drying under normal condition |

A test is made under the above mentioned condition , and it is kept for 2 hours in the normal

IR Reflow profile

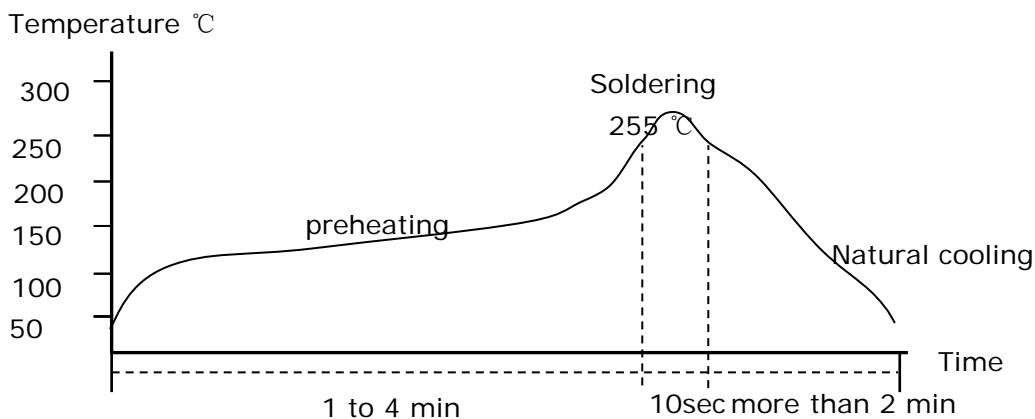

Temperature and humidity . After that , no mechanical and electrical defect should be found .

| | | | | | |
|----------------------|--------|----------------------|--------------------|------------------|---|
| 客戶名稱 CUSTOMER | | 客戶品名 CUSTOMER P/N | | 版本 REV. | A |
| 產品類型 PRODUCT TYPE | 貼片共模電感 | 愛倫品名 Aillen P/N | ALMPRI-5020-SERIES | 文件編號 FILE NO. | |

八. 包裝方式/PACKING LIST

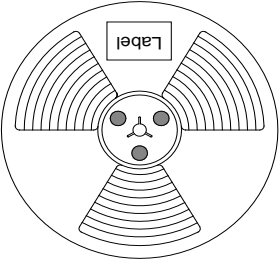
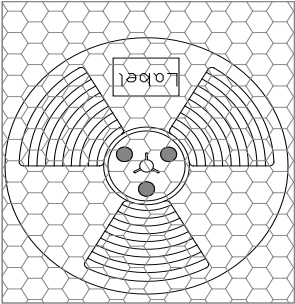
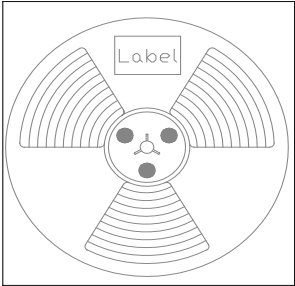
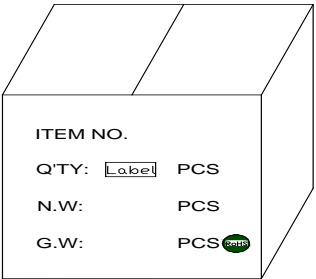
| | |
|---|--|
|  | <p>1、輪盤規格：13(直徑330mm) 數量：2500PCS/盤</p> |
|  | <p>2、數量：2500PCS/袋.</p> |
|  | <p>3、數量：2500PCS/盒</p> |
|  | <p>4、數量：25000PCS/箱.</p> |