

1 Brief introduction of product 产品简介

1.1 TYPE 产品类别: DCF-Y1/X1

1.2 Construction and main materials of products 产品结构和主要材料

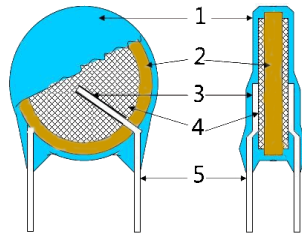

1.3 Applications 用途

No.	Main Construction 主要结构	Materials、Specification 材料、规格	Note 备注
1	Sealed Material 封装材料	Blue powder epoxy resin 蓝色粉末环氧树脂	UL94V-0
2	Ceramic disc 陶瓷片	Ceramic disc 陶瓷	-/-
3	Solder 焊料	Sn97.5-Ag2.0-Cu0.5	-/-
4	Electrodes 电极	Ag 银/Cu 铜	-/-
5	Leads wire 金属引线	CP wire Ø 0.56mm 镀锡铜包钢线	-/-

Ideal for use as X/Y capacitors for AC line filter, electromagnetic interference suppression and primary-secondary coupling on switching power supplies and AC adapters. Ideal for use on D-A isolation and noise absorption for DAA modems without transformers.

用作电源滤波、抑制电源电磁干扰、初次级耦合、开关电源、电源适配器等。也用作直-交流隔离及无变压器数据存取装置的噪音吸收等。

1.4 Hazardous Substances Compliance: All products pass following compliance or standard: ROHS; REACH; PAHS; HF; and Phthalates-Phthalates Regulation.

产品有害物质法规符合性: 产品符合 ROHS; REACH; PAHS; HF; 邻苯二甲酸盐等法规。

1.5 Electrical Specifications 电气特性

Item 项目	Specification 标准要求	
Climatic Category 气候类别 Passive Flammability Class 阻燃等级	40/125/21/B	
Operating Temperature 使用温度范围	-40℃~+125℃	
Capacitance(C),Dissipation(tgδ)Testing at 容量、损耗测试条件	1) Standard atmospheric condition 标准大气压*	
	2)1Vr.m.s,1KHz/100KHz	
Quality Factor(Q)/Dissipation(tgδ) 介质损耗	NP0、SL: ≤2.5‰ (CR≥50pF) ; ≤5‰ (5pF≤CR<50pF) Y5P、Y5U、Y5V : tgδ≤2.5%	
Capacitance Range 系列产品容量范围	5pf~4700pF	
Capacitance Tolerance 容量偏差	J: ±5%, K: ±10% , M: ±20%	
Rated Working Voltage 额定电压	Series 1 Y1/X1	Series 2 Y1/X1
	250VAC/400VAC (50/60Hz) (50/60Hz)	400VAC/440VAC (50/60Hz)
Withstand Voltage Between 端子间耐压	4000VAC	
Insulation Resistance(I.R) 绝缘电阻	≥10000MΩ	
Temperature Characteristic 温度特性	NP0、SL、Y5P、Y5U、Y5V	
Flame Retardant Epoxy Resin(coating) 阻燃环氧树脂封装	Conforming to UL94V-0 standards 符合 UL94V-0 标准	

*Standard atmospheric condition is as follows:



- 1)Temperature:25±2°C
- 2)Relative humidity:45~75%
- 3)Atmospheric pressure:86~106kPa(860~1060 mbar)

2. Part number system 产品代码

DCF	102	M	Y5U	G	0	L	B	0	(**)
1	2	3	4	5	6	7	8	9	10

1 Product Categories 产品类别代码:

DCF: 安规交流瓷介电容器 Safety Standard Recognized AC Disc Ceramic Capacitors

2 Capacitance Code 电容量代码:

Rated Capacitance 标称电容量

100: 10pF 101: 100pF 102: 1000pF
103: 10nF 509: 5Pf

3 Capacitance Tolerance 电容量允许偏差:

C: ±0.25pf D: ±0.5pf J: ±5% K: ±10% M: ±20%

4 Capacitance Characteristic 温度系数/温度特性:

CH SL Y5P Y5U Y5V

5 Rated Voltage 额定电压:

G=Y1/X1=250VAC/400VAC

K=Y1/X1=400VAC/440VAC

6 Lead Space 引线间距 (mm): (线型图示见附录)

7=7.5 0=10.0

7 Lead Style(refer to the attached page) 引线形状 (线型图示见附录)

L: long straight lead M: short straight lead J: single bend K: single outside bend W: double bend
L: 直引线长脚 M: 直引线短脚 J: 单内弯 K: 单外弯 W: 双弯

P: Keep bending

P: 直弯

8 Package 包装:

Length categorization of packed and bulk lead (refer to the attached page for the taping picture)

包装及散装引线长度分类(编带图示见附录)

T: Taping 编带 Hole space 孔距:12.7mm

S: Taping 编带 Hole space 孔距:15mm

B: Bulk 散装

Pin Length 切脚长 (Bulk and Short Pin 散装短脚品):

35=3.5±0.5mm 50=5.0±0.5mm 80=8.0±1.0mm 10=10.0±1.0mm

9 Green Marking 环保标识 : (Environmental compliance 环保符合性):

0: Green*环保产品

* Compliance ROHS: REACH; PAHS; HF; and Phthalates-Phthalates

符合 ROHS、REACH、卤素、邻苯二甲酸盐、多环芳香烃

10 Inside Management Code 内部管理代码

3 Specification Form 规格表

The table lists only G rated voltage series, K series shares all the features except the rated voltage.

本表列明额定电压 Y1 250VAC 系列规格（G 系列），Y1 400VAC 系列规格（K 系列）仅额定电压值不同。

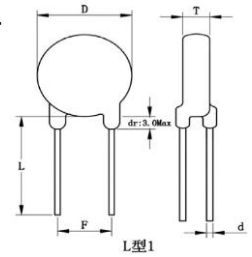

3.1 Normal Specification Form of DCF-Y1/X1

DCF-Y1/X1 标准品规格表

Part Number	Rated Capacitance (pf)	Temperature Characteristic	Capacitance Tolerance	Dimension (mm)		Spacing F (mm)	Diameter d (mm)
				D max	T max		
DCF101KY5PG0---	100	Y5P	K	7.0	5.5	10.0	0.56
DCF151KY5PG0---	150						
DCF181KY5PG0---	180						
DCF221KY5PG0---	220						
DCF271KY5PG0---	270						
DCF331KY5PG0---	330						
DCF391KY5PG0---	390						
DCF471KY5PG0---	470						
DCF561KY5PG0---	560						
DCF681KY5PG0---	680						
DCF102KY5PG0---	1000						
DCF122KY5PG0---	1200						
DCF152KY5PG0---	1500						
DCF222KY5PG0---	2200						
DCF471KY5UG0---	470			Y5U	M		
DCF681KY5UG0---	680						
DCF102MY5UG0---	1000						
DCF122MY5UG0---	1200						
DCF152MY5UG0---	1500						
DCF182MY5UG0---	1800						
DCF222MY5UG0---	2200						
DCF222MY5UG0---	2200						
DCF332MY5UG0---	3300						
DCF392MY5UG0---	3900						
DCF472MY5UG0---	4700						
DCF102MY5VG0---	1000	Y5V	M			7.0	5.5
DCF152MY5VG0---	1500						
DCF182MY5VG0---	1800						
DCF222MY5VG0---	2200						
DCF272MY5VG0---	2700						
DCF332MY5VG0---	3300						
DCF392MY5VG0---	3900						
DCF472MY5VG0---	4700						



3.2 Reduce Specification Form of DCF-Y1/X1

DCF-Y1/X1 小型化产品规格表

Part Number	Rated Capacitance (pf)	Temperature Characteristic	Capacitance Tolerance	Dimension (mm)		Spacing F (mm)	Diameter d (mm)
				D max	T max		
DCF101KY5PG0---	100	Y5P	K	7.0	5.5	10.0	0.56
DCF221KY5PG0---	220			7.0	5.5	10.0	0.56
DCF331KY5PG0---	330			8.0	5.5	10.0	0.56
DCF471KY5PG0---	470			9.0	5.5	10.0	0.56
DCF681KY5PG0---	680			10.0	5.5	10.0	0.56
DCF102KY5PG0---	1000			11.0	5.5	10.0	0.56
DCF152MY5VG0---	1500	Y5V	M	7.0	5.5	10.0	0.56
DCF222MY5VG0---	2200			10.0	5.5	10.0	0.56
DCF332MY5VG0---	3300			12.0	5.5	10.0	0.56
DCF472MY5VG0---	4700			13.0	5.5	10.0	0.56

products in the above table are designed only for customers that are (1) limited by the room of product installation; (2) after lower purchasing unit price. Compared with the standardized products, reduce specification products have limited safety margin. Therefore, customers who have higher demand in quality are not recommended to refer to it.

本表产品仅为满足（1）部分客户因受产品安装空间限制及（2）部分追求较低采购单价的客户而设计，相对标准产品，小型化产品安全边际有限，对质量要求较高的客户不建议使用。

3.3 Higher Reliability Specification Form of DCF-Y1/X1

更高可靠性的 DCF-Y1/X1 系列电容器规格表









Part Number	Rated Capacitance pF	Temperature Characteristic	Capacitance Tolerance	Dimension (mm)		Spacing F (mm)	Diameter d (mm)
				D max	T max		
DCF101KY5PG0--- (LY)	100	Y5P	K	8.0	7.0	10.0	0.56
DCF221KY5PG0--- (LY)	220	Y5P		7.5	7.0	10.0	0.56
DCF331KY5PG0--- (LY)	330	Y5P		8.5	7.0	10.0	0.56
DCF471KY5PG0--- (LY)	470	Y5P		9.5	7.0	10.0	0.56
DCF681KY5UG0--- (LY)	680	Y5U		8.5	7.0	10.0	0.56
DCF102MY5UG0--- (LY)	1000	Y5U	M	9.5	7.0	10.0	0.56
DCF152MY5UG0--- (LY)	1500	Y5U		11.0	7.0	10.0	0.56
DCF222MY5UG0--- (LY)	2200	Y5U		12.5	7.0	10.0	0.56
DCF222MY5VG0--- (LY)	2200	Y5V		10.0	7.0	10.0	0.56

To meet customer's requirements for higher shock resistance which could pass the surge test of 6KV and higher dielectric strength (6KVAC withstand voltage), we design and manufacture the series of safety capacitor.





为了满足客户对电容器更高抗冲击性能要求(能通过 6KV 浪涌实验)及抗电强度(耐压 6KVAC)要求，我们设计制造该系列安规电容器。

4 Approval, Standard, Rated Voltage and File No. 安规标准及认证

4.1 DCF- X1/Y1 (X1/Y1=400VAC/250VAC)

Safety Organization 安规机构	Standard No. 标准编号	File No. 证书编号	Rated Voltage 额定电压	Approved Monogram 安规符号及国家(地区)	
UL/CUL	UL 60384-14	E252221	X1 400VAC/440VAC Y1 250VAC/400VAC		USA/Canada
CQC	GB/T6346.14-2015	CQC04001011968	X1 400VAC/440VAC Y1 250VAC/400VAC		China
VDE	EN 60384-14(VDE 0565 -1-1):2014-04 EN60384-14:13-08 IEC60384-14(ed.4)	40022942	X1 400VAC/440VAC Y1 250VAC/400VAC		Germany
ENEC					European Economic Community
ESTI	EN60384-14:13	19.0002	X1 400VAC/440VAC Y1 250VAC/400VAC		Switzerland
DEMKO	EN60384-14:2013	D06704	X1 400VAC/440VAC Y1 250VAC/400VAC		Denmark
NEMKO	EN60384-14:2013	P11213665	X1 400VAC/440VAC Y1 250VAC/400VAC		Norway
SEMKO	EN60384-14:2013	1616558	X1 400VAC/440VAC Y1 250VAC/400VAC		Sweden
FIMKO	EN60384-14:2013	NCS/FI 29418	X1 400VAC Y1 400VAC		Finland

4.2 DCF- X1/Y1 (X1/Y1=440VAC/400VAC)

Safety Organization 安规机构	Standard No. 标准编号	File No. 证书编号	Rated Voltage 额定电压	Approved Monogram 安规符号及国家(地区)	
CQC	GB/T6346.14-2015	CQC04001011968	X1 400VAC/440VAC Y1 250VAC/400VAC		China
UL/CUL	UL 60384-14	E252221	X1 400VAC/440VAC Y1 250VAC/400VAC		USA/Canada
VDE	EN 60384-14(VDE 0565 -1-1):2014-04 EN60384-14:13-08 IEC60384-14(ed.4)	40022942	X1 400VAC/440VAC Y1 250VAC/400VAC		Germany
ENEC					European Economic Community

5 Marking 标志

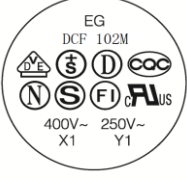
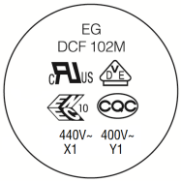
Type 类型	X1/Y1 400VAC/250VAC	X1 /Y1 440VAC/400VAC
Marking 标志		
Logo Mark 制造厂商标	EG	EG
Type Designation 产品型号	DCF	DCF
Capacitance and Tolerance 标称容量、偏差	102M	102M
Sub-Class Code and Rated Voltage 类别、额定电压	X1 400V~ Y1 250V~	X1 440V~ Y1 400V~

6 Packing in bulk 包装说明

6.1 Outside packing box overlook 外包装箱尺寸

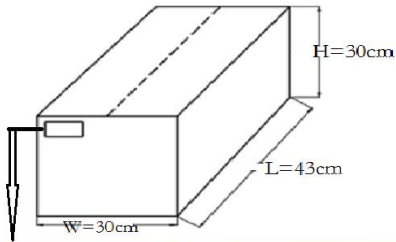

顾客名称	L03	RoHS
产品名称	安规交流瓷介电容器(Y)	
产品代码	DCF102MY5UG0LB0	QC 2016-9-28 Pass
顾客代码	638013-522BLN	
批号	24 Kpcs 批号 20160927366A	EBC
制造商	东莞市易利嘉电子有限公司 Easy-gather Electronic Co.,Ltd	

编带包装内盒

散件包装内盒尺寸: W*L*H=20*28*14.2cm/20*28*10cm

6.2 Inner packing box 内包装箱尺寸

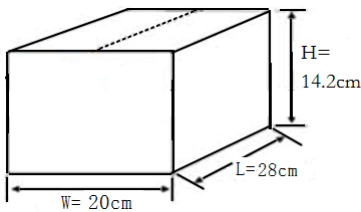

散件包装内盒

散件包装内盒尺寸: W*L*H=20*28*14.2cm/20*28*10cm



折叠式

Taping/Ammo

编带包装内盒

front view 主视图

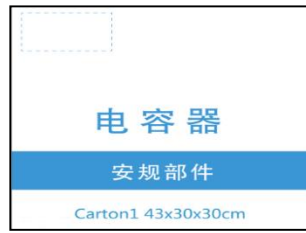

back view 后视图

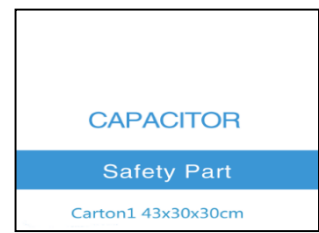

Left drawing 左视图

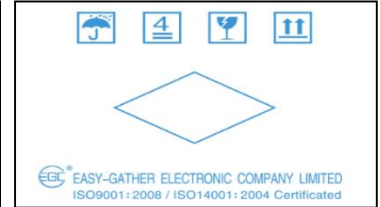

Right drawing 右视图

6.3 Bag package picture 内袋包装实物图片:



6.4 Bag mark photo 内袋标签图示:

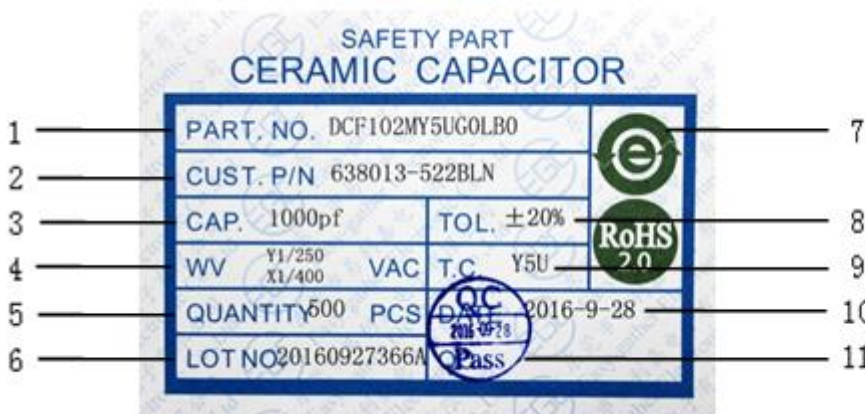

- 1 PART. NO. 规格代码
- 2 CUST. P/N 客户料号
- 3 RATED CAP.ACITY 标称容量
- 4 RATED VOLTAGE 标称电压
- 5 QUANTITY 包装数量
- 6 LOTNO. 生产批号
- 7 ENVIRONMENT MARK 环保标识
- 8 TOLENCE 容量偏差
- 9 温度特性
- 10 PACKAGE DATE 包装日期
- 11 QC SEAL QC合格章



7 Regulation in usage 使用规则

7.1 OPERATING VOLTAGE 使用电压

According to IEC standard, when selecting safety capacitors, the nominal voltage of the capacitor needs to be equal to or greater than the nominal voltage of the connected power system. When using safety capacitors, the voltage applied between the terminals should be lower than the rated voltage. 1): When the AC voltage is superimposed on the DC voltage, the peak voltage should be lower than the rated voltage. 2): When using AC voltage or pulse voltage, the peak voltage should also be lower than the rated voltage. In addition, please consider the possibility of abnormal voltage (surge voltage, static electricity, switch spiking voltage), the abnormal voltage should also be less than the rated voltage (as shown below).

Please strictly follow the specified test conditions (voltage, time, waveform), and ensure good contact between all parts when used in AC primary circuit for AC voltage withstand test. When the voltage is applied, the voltage should gradually increase from 0 to the test voltage. When a spark discharge is generated due to an imperfect connection to a test device, or when a voltage is applied to a non-zero-crossing enabled test device, abnormal voltages higher than the specified voltage may be generated to cause defects.

For the Y1 capacitor, make sure that the capacitor is placed in a relative humidity of no more than 75% for 24 hours before carrying out for a withstand voltage test (4000VAC)

IEC 标准规定, 选择抑制电磁干扰电容器时, 其额定电压等于或大于所连接的电源系统标称电压。电路设计使用电容器时, 在端子间施加的电压应该低于额定电压: (1) 在直流电压上重叠交流电压时, 峰值电压应该低于额定电压; (2) 使用交流电压或脉冲电压时, 尖峰电压也应该低于额定电压。另外, 要确认使用的电源设备是不是有可能施加异常电压(浪涌电压、静电、开关突峰电压), 如果产生则异常电压也应该低于额定电压(如下图所示)。

交流初次回路时, 用于防止杂波的电容器其交流耐压试验的实验条件不能超过规定的条件(电压、时间、波形), 并且确保接触良好, 防止接触不良发生。施加电压时, 电压应该从 0 开始逐步增加至试验电压。当由于与测试设备的不完美连接而产生火花放电, 或者在非过零启动的测试设备上施加电压时, 可能会产生高于指定电压的异常电压导致缺陷发生。

Y1 电容器, 在进行耐压试验(4000VAC)前, 确保电容器在相对湿度不大于 75% 的空气中放置 24 小时。

Voltage	DC Voltage	DC+AC Voltage	AC Voltage	Pulse Voltage(1)	Pulse Voltage(2)
Positional Measurement					

7.2 OPERATING AND STORAGE ENVIRONMENT 使用和储存环境

The insulating coating of capacitors does not form a perfect seal; therefore, do not use or store capacitors in a corrosive atmosphere, especially where chloride gas, sulfide gas, acid, alkali, salt or the likes are present. And avoid exposure to moisture. Before cleaning, bonding, or molding this product, verify that these processes do not affect product quality by testing the performance of a cleaned, bonded or molded product in the intended equipment. Store the capacitors where the temperature and relative humidity do not exceed -10 to 40°C and 15 to 75%.

Being exposed in air for too long may result in attenuation of leads' welding performance.

Please use capacitors within 12 months and the date on packaging label should prevail. If overdue, the capacitors should be confirmed the performance before use.

电容器的绝缘外层不可能完全密封。因此, 不要在下列大气环境下使用或者储存电容器: 含有腐蚀性气体、特别是放置有含氯气体、含硫气体的地方; 放置有酸、碱、盐等物质的地方。也要尽量避免将电容器暴露在潮湿的空气中。在清洗、焊接或者成型产品前要确认这些过程不会影响产品的品质, 这种确认可以通过使用特定装备来测试清洗过、焊接过或者成型过的产品。电容器储存温度为 -10°C~40°C, 相对湿度为 15%~75%。

长时间暴露在空气中会导致产品引线焊接性能衰减。

请在 12 个月内使用电容器(以包装标签日期为准)。如超期, 应进行性能确认后再使用。

7.3 VIBRATION AND IMPACT 振动和撞击

Do not expose a capacitor or its leads to excessive shock or vibration during use.

使用时, 避免电容器及电容器引线受到过多的撞击或者振动。

7.4 SOLDERING 焊接

When soldering this product to a PCB/PWB, do not exceed the solder heat resistance specification of the capacitor. Subjecting this product to excessive heating could melt the internal junction solder and may result in thermal shocks that can crack the ceramic element.

Failure to follow the above cautions may result, worst case in a short circuit and cause fuming or partial dispersion when the product is used.

Welding condition:

(1) Wave-soldering: 260°C±5°C, 5 seconds at most.

The severe degree of welding do not exceed: 1) 260°C, 8 seconds; 2) 270°C, 3 seconds.)

(2) Solder with the soldering bit: temperature of the tip of soldering iron do not exceed 350°C and time should be less than 5 seconds.

焊接条件:

(1) 波峰焊: 260°C±5°C、焊接时间小于 5S(焊接严酷度不能超过 1)260°C,8S;2)270°C,3S)

(2) 使用烙铁焊接: 烙铁尖端温度不超过 350°C, 焊接时间小于 5S。

在把产品焊接到印刷电路板过程中, 不要超过电容器规格中有关耐焊接热的规定。如果产品超过耐焊接热可能会熔化用于内部连接的焊料, 产生热冲击而导致陶瓷材料破裂。

上述原因导致产品在使用时出现下列最严重的失效现象: 短路引起冒烟或者局部碎裂。

Flow soldering recommended condition

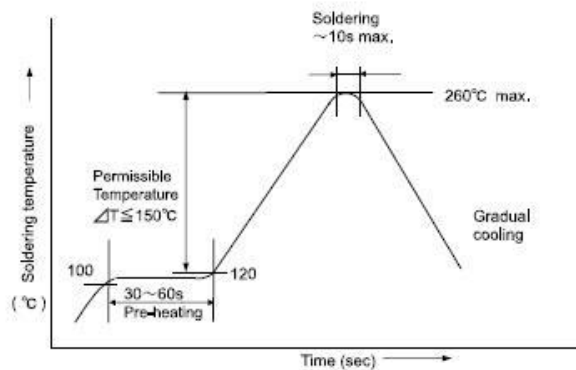

7.5 Sample and environment for test should be confirmed

耐压试验、脉冲试验被试验样品及试验环境应符合:

Temperature 环境温度: 小于 35 °C

Relative humidity 相对湿度: 25~75%

TEST SAMPLE: The sample is required to store under a maximum relative humidity of 75% for minimum 24 hours.

试验样品: 应在相对湿度不大于 75%条件下放置 24 小时以上。

8 Characteristics and test conditions 电气特性和测试条件

8.1 Test condition: Unless otherwise specified, the standard range of atmospheric

Conditions for marking measurements and test is conducted in the following ambient

测试条件: 除非另有规定, 测试应在下列标准大气条件下进行:

Ambient temperature 环境温度: 15~35 °C Relative humidity 相对湿度: 25~75%.

If there may be any doubt on the results, measurements shall be made within the Following limits.

如对测试结果有任何疑问, 则按以下条件测试: temperature 环境温度: 20±2°C, Relative

humidity 相对湿度: 60~70%.

Default frequency of the related alternating current tests: 50Hz

交流电源相关测试默认频率: 50Hz

8.2 Specification and test methods 技术指标及试验方法

No	Item 项目	Test method 试验方法	Specification 技术参数
1	Appearance 外观	The appearance shall be inspected by naked eyes. 用肉眼检查外观	No marked defect on appearance 外观无显著缺陷
2	Dimensions 尺寸	The dimensions shall be measured with slide calipers 用游标卡尺测量尺寸	Dimensions of capacitor and taping shall satisfy specified requirement. 电容器的外型尺寸和编带尺寸应满足规定



3	Marking 标志	The marking shall be checked by 4x magnifying glass. 用 4 倍放大镜检查标志	Legible marking 标志清晰易辨认
4	Capacitance and tolerance 容量和误差	The capacitance shall be measured at 25°C with 1KHz 1±0.2 Vrms. 电容量测量条件: 25°C, 1KHz 1±0.2 Vrms	Refer to 1.5 参照 1.5
5	Dissipation factor(D.F) 介质损耗	The dissipation factor shall be measured at 25°C with 1KHz 1±0.2 Vrms. 介质损耗测量条件: 25°C, 1KHz 1±0.2 Vrms.	Refer to 1.5 参照 1.5
6	Insulation resistance 绝缘电阻	The insulation resistance shall be measured with 100VDC within 60±5 sec of charging. 绝缘电阻测量条件: 500VDC, 充电 60±5 秒	Test A
			Test B or Test C
			R (MΩ)
			R (MΩ)
			10000
7	Dielectric Strength (Voltage Proof) 耐电压	Between Lead Wires 引线之间	The capacitor should not be damaged when test voltages of table below are applied between the lead wires for 60 sec. 在引线之间施加下表所示试验电压, 施加时间 60s, 电容器不会损坏。
		Type 类型	Test Voltage 试验电压
		Y1/X1	AC4000V(r.m.s.)
	Body Insulation 本体绝缘	First, the terminals of the capacitor should be connected together. Then, as shown in figure below, a metal foil should be closely wrapped around the body of the capacitor to the distance of about 3 to 4mm from each terminal. Then, the capacitor should be inserted into a container filled with metal balls of about 1mm diameter. Finally, ac voltage of table below is applied for 60 sec. between the capacitor lead wires and metal balls. 首先, 电容器引线终端应连接在一起。然后将金属箔紧密缠绕在电容器本体上距各个引出端大约 3 到 4mm 的地方。并将电容器插入充满直径 1mm 金属球的容器内 (如下图所示)。最后, 在电容器引线和金属球之间施加如下表所示的交流电压, 时间 60s.	No failure 不允许有失败
	Type 类型	Test Voltage 试验电压	
	Y1/X1	AC4000V(r.m.s.)	

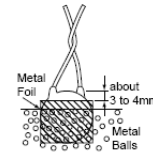

8.3 Mechanical characteristics and methods 机械特性及测试方法

No	Item 项目	Test method 试验方法	Specification 技术参数
1	Robustness of Termination 引出端强度	The capacitor body shall be held in such a manner so that the axis of the lead is vertical. The tensile force of 10N(for lead of $\varnothing 0.6 \sim \varnothing 0.8\text{mm}$) shall be applied to the lead in a direction of its axis and acting in a direction away from the body of the capacitor for 10±1 seconds. 使用某种方式固定电容器的本体, 并使引线的轴心与本体垂直。为使引线脱离电容器本体, 在本体反向引线端沿轴心施加 10N 的拉力 (引线直径为 0.56mm~0.8mm), 持续 10±1s。	The capacitor shall be no broken and the lead shall be no loosened or cut off. 电容器未损坏, 并且引线未松动或者断开

8.4 Endurance characteristics and test methods 耐用特性以及测试方法

No	Item 项目	Test method 试验方法	Specification 技术参数		
1	Solderability Of leads 引线可焊性	The lead wire of a capacitor should be dipped into molten solder for 2±0.5sec. The depth of immersion is up to about 1.5 to 2.0mm from the root of lead wires. Temp. of solder: Lead Free solder(Sn-3Ag-0.5Cu) 245±5°C H63 Eutectic Solder 235±5°C 引线应浸入熔融的焊料里 2±0.5 秒，浸入深度大约为 1.5~2mm（从引线底端算起） 焊料温度： 无铅焊料（锡-3 银-0.5 铜）245±5°C H63 共晶焊料 235±5°C	A new uniform coating of solder shall cover a minimum of 3/4 of the surface being immersed 新的焊料层应均匀覆盖至少 3/4 被浸入表面		
2	Resistance to Soldering heat 耐焊接热	Temperature of solder bath 260±5°C. The immersing depth of lead shall be a position 2-0.5mm from the seating plane, using a thermal screen. The thickness of the screen is 1.5±0.5mm. The immersion time shall be 10±1 seconds. Post-treatment: The capacitor shall be preserved at the standard atmospheric condition for 1 to 2 hours. 焊浴温度：260±5°C。引线浸入深度：离底座 2-0.5mm。使用绝热板（厚度为 1.5±0.5mm）。浸入时间：10±1 秒。 后处理：电容器应在标准大气压条件下放置 1-2 小时。	Appearance 外观	No visible damage 没有明显损坏	
			Dissipation Factor 介质损耗	As spec 参照规格书	
			Capacitance Change 电容量变化 (ΔC/C0)	Within ±12% 低于±12%	
			Voltage proof (between leads) 耐电压（引线间）	Refer to Item 8.2.7 参照 8.2.7	
3	Solvent Resistance 耐溶剂性	The capacitor shall be immersed into isopropyl alcohol for 30±5nds. seco 电容器应浸入异丙醇中 30±5 秒	Appearance 外观	No visible damage 无明显损坏 Legible marking 标志清晰	
4	Damp heat with load 稳态湿热	The rated voltage shall be applied continuously to the capacitor for 21 days (500±8hours) at a temperature of 85°C±2°C and a relative humidity of 85%±5%. Pre-treatment:The capacitor shall be stored at a temperature of 85°C±2°C for 1 hour ,and then the capacitor shall be recovered for 24±2 hours. Post-treatment:The capacitor shall be stored for 1 to 2 hours at the standard atmospheric condition. (Temperature:15 to 35°C,Relative humidity:45 to 75%,Atmospheric pressure:86 to 106kPa) 在 85°C±2°C、相对湿度 85%±5%条件下，对电容器施加额定电压 21 天（500±8 小时）。 预处理：在温度 85°C±2°C下储存电容器 1 小时，然后电容器恢复 24±2 小时。后处理：在标准大气压下储存电容器 1-2 小时。 （温度：15-35°C，相对湿度：45-75%，大气压力：86-106 千帕）	Capacitance Change 电容量变化 (ΔC/C0)	Within ±15% 低于 ±15%	
			Dissipation Factor 介质损耗	tgδ≤参照 初始值的 2 倍	
			Insulation resistance 绝缘电阻	Test A	Test B or Test C
				R (MΩ)	R (MΩ)
			Dielectric Strength 介电强度	6000	6000
		Refer to Item 8.2.7 参照 8.2.7			

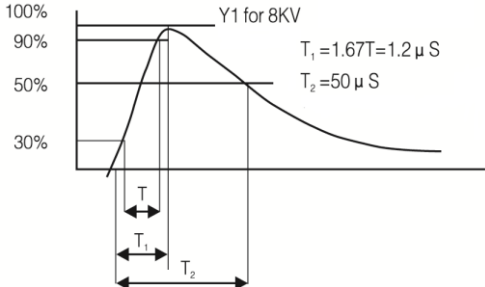
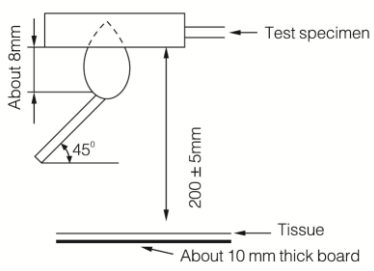

5	Endurance test(life) 耐久性试验 (寿命)	<p>The capacitor shall be subjected to three impulses as shown below. 电容器应经受 3 次脉冲，如下图。</p>  <p>Y1 for 8KV $T_1 = 1.67T = 1.2 \mu S$ $T_2 = 50 \mu S$</p> <p>Then the capacitors are placed at a temperature of 125°C for 1000 hours. Throughout the test, the capacitors are subjected 50Hz/60Hz , 1.7UR voltages, except that once each hour the voltage is increased to 1000 Vrms for 0.1sec. Post-treatment: the capacitor shall be preserved for 24±2 hours at standard atmospheric condition. 然后将电容器放置在 125°C下实验 1000 小时。在整个实验过程中，持续对电容器施加 50Hz/60Hz 1.7UR 电压，每间隔一小时应将电压升高到 1000 Vrms，且持续时间 0.1 秒 后处理：在标准大气压下，电容器恢复 24±2 小时。</p>	Appearance 外观	No visible damage 无明显损坏		
		Capacitance Change 电容量变化 ($\Delta C/C_0$)	Within ±20% 低于 ±20%	Dissipation Factor 介质损耗	$tg\delta \leq$ 参照 初始值的 2 倍	
6	assive flammability 阻燃性	 <p>Length of flame:12mm 火焰长度：12mm Gas burner: Length 35mm min. 煤气燃烧器：至少 35mm Inside diameter:0.5±0.1mm 内径：0.5±0.1mm Outside diameter: 0.9mm min. 外径：最小值 0.9mm Gas: Butane gas purity 95% min. 气体：丁烷气纯度至少 95%</p>	Severity and Requirements 严酷度等级和要求			
			有焰燃烧等级 Flaming Ratings	Severity Level 严酷等级		最大燃烧时间 (S) Maximum flaming time (S)
				Flame is applied for a time (S) against the capacitor volumes range (mm) 针对电容器体积范围 (mm) 施加火焰时间 (S)	Volume 体积	
B	10	30	60	10		
C	10	20	30	30		

Attach page 附录

Structure and lead style
产品外型结构、引线式样

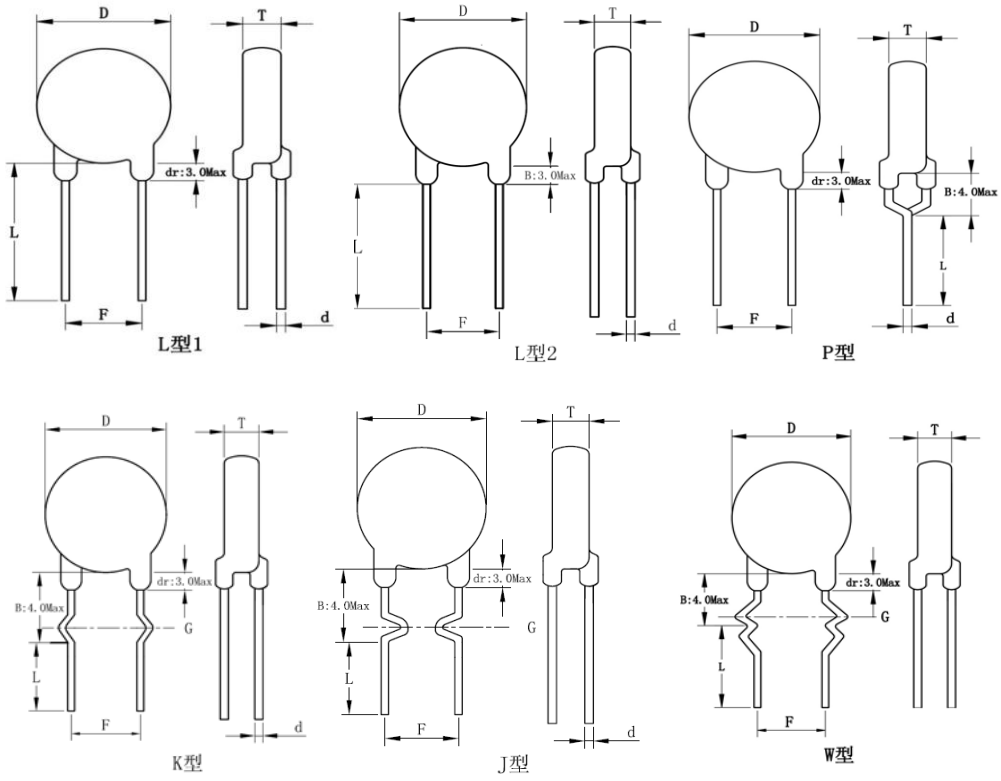

Taping specification
编带产品技术标准

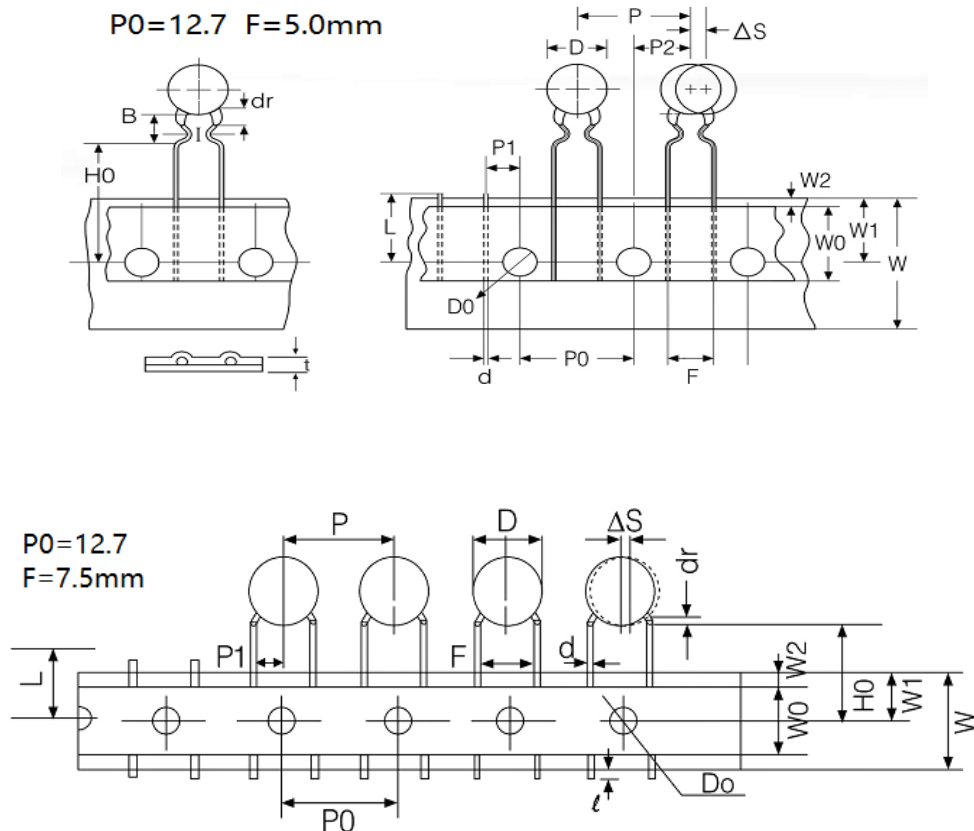

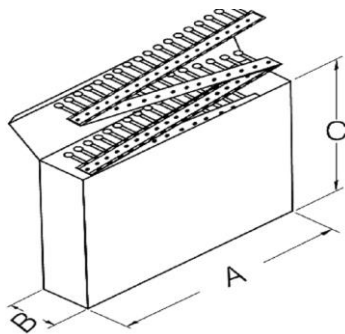
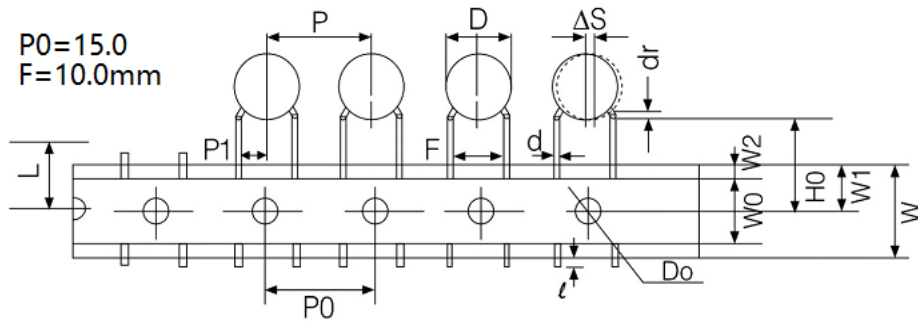
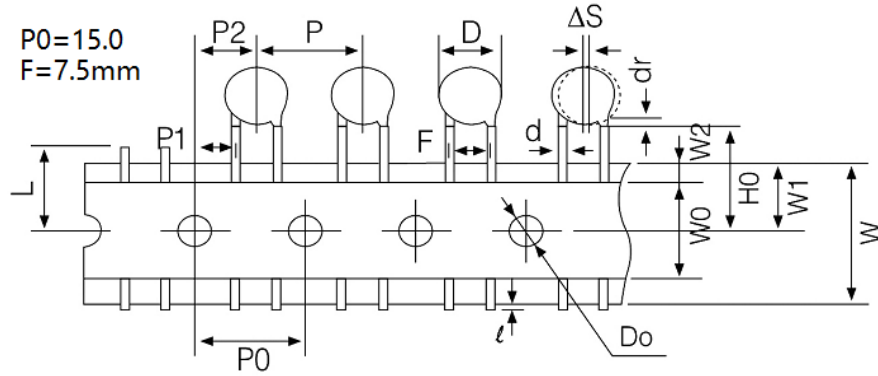
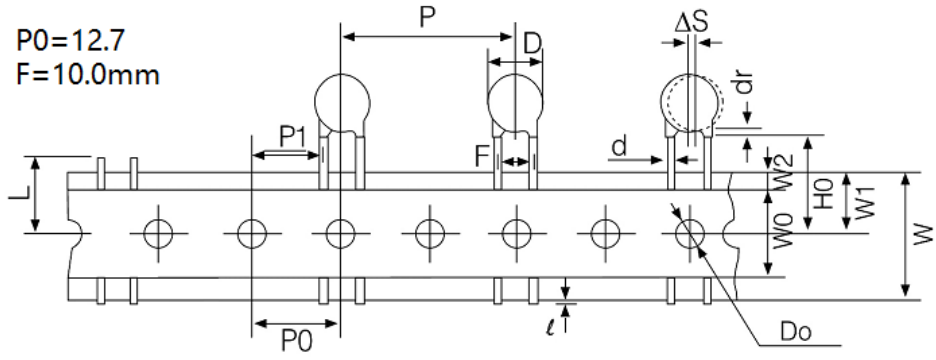

折叠式 Taping/Ammo

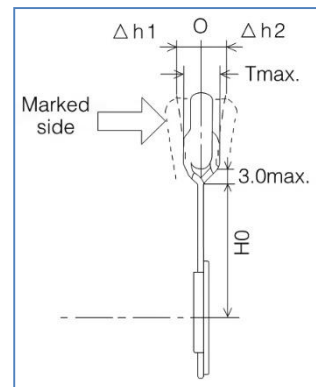
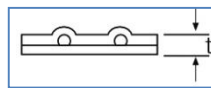

Type DCF-Y1/X1 Series Approval Sheet—DCF-Y1/X1 系列承认书

Taping size sheet 编带尺寸表:(mm)

Type 分类	Symbol 符号	Item 名称	S Taping size requirement S 型编带尺寸要求		T Taping size requirement T 型编带尺寸要求		
Product body 产品本体	F	Lead spacing 引线间距	7.5±1.0	10.0±1.0	5.0-0.2+0.8	7.5±1.0	10.0±1.0
	D	Body diameter 本体直径	Refer to spec 见规格表		Refer to spec 见规格表		
	T	Body thickness 产品本体厚度	Refer to spec 见规格表		Refer to spec 见规格表		
	Dr	Coating extension 包封脚长	3.0Max				
	l	Distance of leads inside crimped 引线内弯距离	/	/	2.5/1.5	5.0/4.0	/
	d	Lead diameter 引线直径	0.56±0.05		0.50±0.05	0.50/0.56±0.05	0.56±0.05
Product carrier tape 产品载体	W	Carrier tape width 载带宽度	18.0±0.5				
	t	Total tape thickness 编带总厚度	0.6±0.2				
	WO	Hold down tape width 粘带宽度	10.0±0.5		8.0±0.5		
	W1	Position of sprocket hole 对输送孔的偏移	9.0±0.5				
	W2	Hold down tape position 粘带边距	1.5±1.5				
	P0	Pitch of sprocket hole 输送孔间距	15.0±0.3		12.7±0.3		
	D0	Diameter of sprocket hole 输送孔直径	4.0±0.3				
Combine product body and product carrier tape 产品本体和载体结合	P	Pitch of component 编带间距	15.0±1.0		12.7±0.3		25.4±1.0
	P1	Length from hole center to lead wire center 对输送孔的偏移	3.75±0.7	5.0±0.7	3.85±0.7		7.7±0.7
	P2	Length from hole center to component center 对输送孔的偏移	7.5±1.3	/	6.35±1.3	/	/
	H0	Distance between reference 引线弯曲位置高度 (L 形引线到产品底部)	DCF、DCG 及 DCH2KV、3KV F=7.5		DCC、DCT、DCS DCH 1KV 及 DCH 2KV、3KV F=5mm		
			L 型引线:20.0-0+2 Kink 引线:18.0-0.5+1.5		L 型引线:20.0-0+2 Kink 引线:16.0-0.5+1.5		
	ΔS	Deviation along tape 本体倾斜	0±2.0				
	Δh1	Deviation across tape 本体倾斜	2.0Max				
	Δh2	Deviation across tape 本体倾斜	2.0Max				
	L	Portion to cut in case of defect 废品切断高度	11.0Max				
	B	Distance between the bottom of product body and assembly positioning 产品本体底部与装配定位处距离	Kink 引线:4.0Max				
ℓ	Protrusion length 突出长度	0.5-1.0		/			

