

### 1.Part Number System

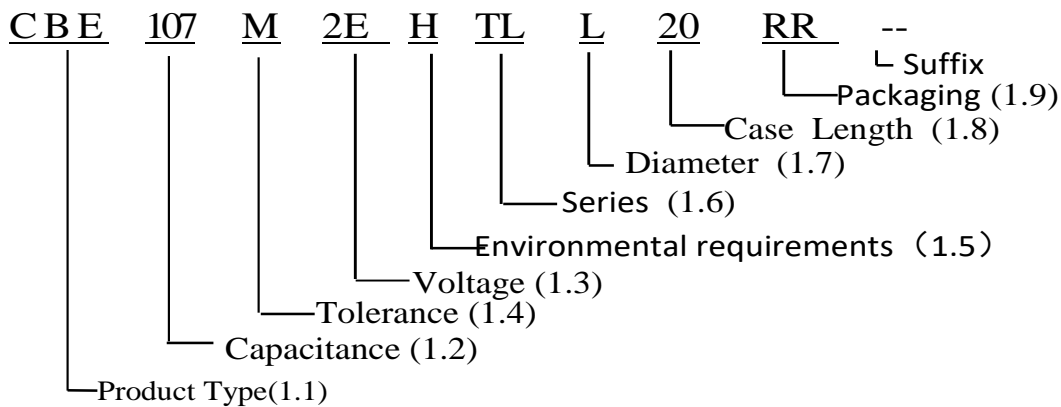

#### 1.1 Product Type

<b>Code</b>	<b>CBE</b>
<b>Product Type</b>	<b>Radial</b>

#### 1.2 Capacitance code

<b>Code</b>	<b>106</b>	<b>107</b>
Capacitance (μF)	10	100

#### 1.3 Rated voltage code

<b>Code</b>	<b>0J</b>	<b>1A</b>	<b>1C</b>	<b>1E</b>	<b>1V</b>	<b>1H</b>	<b>1J</b>	<b>2A</b>
Voltage (W.V.)	6.3	10	16	25	35	50	63	100

<b>Code</b>	<b>2C</b>	<b>2D</b>	<b>2E</b>	<b>2V</b>	<b>2G</b>	<b>2W</b>
Voltage (W.V.)	160	200	250	350	400	450

#### 1.4 Capacitance tolerance

<b>Code</b>	<b>M</b>	<b>V</b>	<b>R</b>
Tolerance Range	±20%	-10%~+20%	0~+20%

#### 1.5 Environmental requirements

<b>Code</b>	<b>R</b>	<b>H</b>
Environmental requirements	ROHS Requirements	HF Requirements

#### 1.6 Products Series Code:

<b>Code</b>	<b>CDTL</b>
Series	<b>TL</b>

#### 1.7 Diameter

<b>Code</b>	<b>B</b>	<b>C</b>	<b>D</b>	<b>E</b>	<b>F</b>	<b>G</b>	<b>I</b>	<b>J</b>	<b>K</b>	<b>L</b>
Diameter	3	4	5	6.3	8	10	12.5	13	16	18

#### 1.8 Case length

<b>Code</b>	<b>11</b>	<b>1A</b>	<b>1B</b>	<b>20</b>	<b>2A</b>	<b>3A</b>
length(mm)	11	11.5	12.5	20	21.5	31.5

### 1.9 Packaging:

Code	RR	T2	TB	T3	T5
Packaging	Bulk	Lead Pitch=2.0mm Taping	Lead Pitch=2.5mm Taping	Lead Pitch=3.5mm Taping	Lead Pitch=5.0mm Taping
Code	T7	CA	CB	CC	CD
Packaging	Lead Pitch=7.5mm Taping	Cut the feet long=3.0mm	Cut the feet long=3.5mm	Cut the feet long=4.0mm	Cut the feet long=4.5mm

注：产品切脚长度，以 A=3.0mm 开始，每增加 0.5mm，英文字向前推一位，如下表：

切脚长度(mm)	代码
3.0±0.5	CA
3.5±0.5	CB
4.0±0.5	CC
4.5±0.5	CD
5.0±0.5	CE
依次类推-----	

## 2. Construction

Single ended type to be produced to fix the terminals to anode and cathode foil, and wind together with paper, and then wound element to be impregnated with electrolyte will be enclosed in an aluminum case. Finally sealed up tightly with end seal rubber, then finished by putting on the vinyl sleeve.

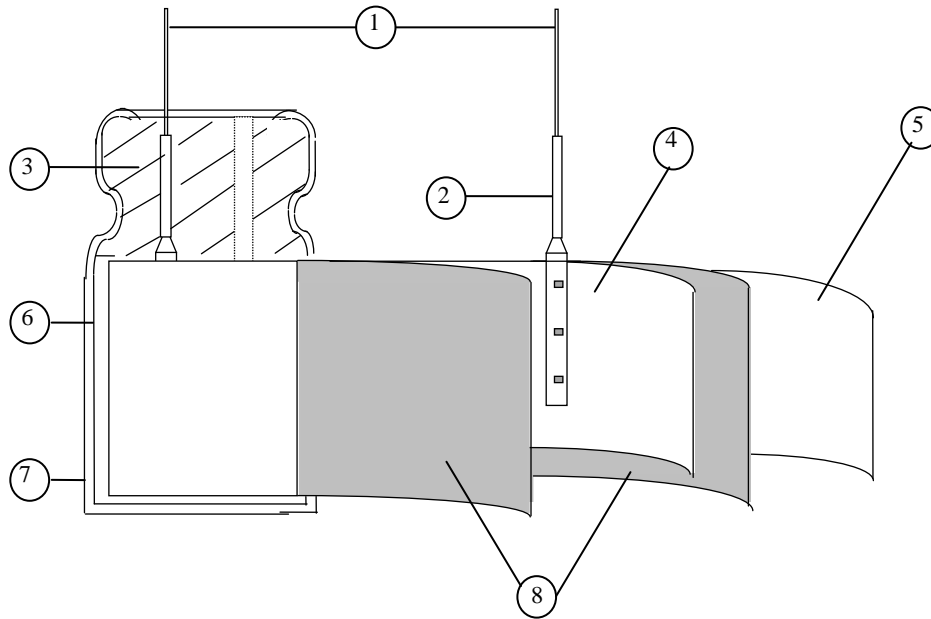

No	Component	Material
1	Lead line	Tinned CP wire (Pb Free)
2	Terminal	Aluminum wire
3	Sealing Material	Rubber
4	Al-Foil (+)	Formed aluminum foil
5	Al-Foil (-)	Etched aluminum foil or formed aluminum foil
6	Case	Aluminum case
7	Sleeve	PET
8	Separator	Electrolyte paper

## 3.Characteristics

### Standard atmospheric conditions

Unless otherwise specified, the standard range of atmospheric conditions for making measurements and tests is as follows:

Ambient temperature	: 15°C to 35°C
Relative humidity	: 45% to 85%
Air pressure	: 86kPa to 106kPa

If there is any doubt about the results, measurement shall be made within the following conditions:

Ambient temperature	: 20°C ± 2°C
Relative humidity	: 60% to 70%
Air pressure	: 86kPa to 106kPa

### Operating temperature range

The ambient temperature range at which the capacitor can be operated continuously at rated voltage is (6.3~100WV) -40°C to 105°C; (160~450WV) -25°C to 105°C.

As to the detailed information, please refer to table 1

Table 1

ITEM		PERFORMANCE								
3.1	Rated Voltage (WV)	WV (V.DC)	6.3	10	16	25	35	50	63	100
		SV (V.DC)	8	13	20	32	44	63	79	125
	Surge Voltage (SV)	WV (V.DC)	160	200	250	350	400	450		
		SV (V.DC)	200	250	300	400	450	500		
3.2	Nominal capacitance (Tolerance)	<p><b>&lt;Condition&gt;</b>                      Measuring Frequency : 120Hz ± 12Hz                      Measuring Voltage : Not more than 0.5Vrms                      Measuring Temperature : 20 ± 2°C</p> <p><b>&lt;Criteria&gt;</b>                      Shall be within the specified capacitance tolerance.</p>								
3.3	Leakage current	<p><b>&lt;Condition&gt;</b>                      Connecting the capacitor with a protective resistor (1kΩ ± 10Ω) in series for 2 minutes, and then, measure leakage current.</p> <p><b>&lt;Criteria&gt;</b>                      6.3~100V:                      I (μA) ≤ 0.01CV or 3 (μA) whichever is greater.                      160~450V: I ≤ 0.03CV + 10 (μA) max after 2 minutes                      I: Leakage current (μA)                      C: Capacitance (μF)                      V: Rated DC working voltage (V)</p>								

3.4	tan $\delta$	<p>&lt;Condition&gt; See 4.2 Nominal capacitance, for measuring frequency, voltage and temperature.</p> <p>&lt;Criteria&gt;</p> <table border="1" data-bbox="501 286 1453 465"> <tr> <td>Working voltage (v)</td> <td>6.3</td> <td>10</td> <td>16</td> <td>25</td> <td>35</td> <td>50</td> <td>63</td> <td>100</td> </tr> <tr> <td>tan <math>\delta</math> (max.)</td> <td>0.26</td> <td>0.22</td> <td>0.18</td> <td>0.16</td> <td>0.14</td> <td>0.12</td> <td>0.10</td> <td>0.08</td> </tr> <tr> <td>Working voltage (v)</td> <td>160</td> <td>200</td> <td>250</td> <td>300</td> <td>350</td> <td>400</td> <td></td> <td></td> </tr> <tr> <td>tan <math>\delta</math> (max.)</td> <td>0.20</td> <td>0.20</td> <td>0.20</td> <td>0.24</td> <td>0.24</td> <td>0.24</td> <td></td> <td></td> </tr> </table>	Working voltage (v)	6.3	10	16	25	35	50	63	100	tan $\delta$ (max.)	0.26	0.22	0.18	0.16	0.14	0.12	0.10	0.08	Working voltage (v)	160	200	250	300	350	400			tan $\delta$ (max.)	0.20	0.20	0.20	0.24	0.24	0.24																													
Working voltage (v)	6.3	10	16	25	35	50	63	100																																																									
tan $\delta$ (max.)	0.26	0.22	0.18	0.16	0.14	0.12	0.10	0.08																																																									
Working voltage (v)	160	200	250	300	350	400																																																											
tan $\delta$ (max.)	0.20	0.20	0.20	0.24	0.24	0.24																																																											
3.5	Terminal strength	<p>&lt;Condition&gt; Tensile strength of terminals Fixed the capacitor, applied force to the terminal in lead out direction for <math>10 \pm 1</math> seconds. Bending strength of terminals Fixed the capacitor, applied force to bent the terminal (1~4 mm from the rubber) for 90° within 2~3 seconds, and then bent it for 90° to its original position within 2~3 seconds.</p> <table border="1" data-bbox="531 792 1410 976"> <tr> <td>Diameter of lead wire</td> <td>Tensile force N (kgf)</td> <td>Bending force N (kgf)</td> </tr> <tr> <td>0.5mm and less</td> <td>5 (0.51)</td> <td>2.5 (0.25)</td> </tr> <tr> <td>Over 0.5mm to 0.8mm</td> <td>10 (1.0)</td> <td>5 (0.51)</td> </tr> </table> <p>&lt;Criteria&gt; No noticeable changes shall be found, no breakage or looseness at the terminal.</p>	Diameter of lead wire	Tensile force N (kgf)	Bending force N (kgf)	0.5mm and less	5 (0.51)	2.5 (0.25)	Over 0.5mm to 0.8mm	10 (1.0)	5 (0.51)																																																						
Diameter of lead wire	Tensile force N (kgf)	Bending force N (kgf)																																																															
0.5mm and less	5 (0.51)	2.5 (0.25)																																																															
Over 0.5mm to 0.8mm	10 (1.0)	5 (0.51)																																																															
3.6	Temperature characteristics	<p>&lt;Condition&gt;</p> <table border="1" data-bbox="501 1126 1406 1420"> <thead> <tr> <th>STEP</th> <th>Testing temperature(°C)</th> <th>Time</th> </tr> </thead> <tbody> <tr> <td>1</td> <td><math>20 \pm 2</math></td> <td>Time to reach thermal equilibrium</td> </tr> <tr> <td>2</td> <td><math>(-40)-25 \pm 3</math></td> <td>Time to reach thermal equilibrium</td> </tr> <tr> <td>3</td> <td><math>20 \pm 2</math></td> <td>Time to reach thermal equilibrium</td> </tr> <tr> <td>4</td> <td><math>105 \pm 2</math></td> <td>Time to reach thermal equilibrium</td> </tr> <tr> <td>5</td> <td><math>20 \pm 2</math></td> <td>Time to reach thermal equilibrium</td> </tr> </tbody> </table> <p>&lt;Criteria&gt;</p> <p>a. At +105°C, capacitance measured shall be within <math>\pm 20\%</math> of its original value at +20°C. tan <math>\delta</math> shall be within the limit of Item 4.4 The leakage current measured shall not more than 8 times of its specified value.</p> <p>b. In step 5, tan <math>\delta</math> shall be within the limit of Item 4.4 The leakage current shall not more than the specified value.</p> <p>c. At -25°C, Impedance (Z) ratio shall not exceed the value of the following table.</p> <table border="1" data-bbox="485 1812 1453 2011"> <tr> <td>Rated Voltage (V)</td> <td>6.3</td> <td>10</td> <td>16</td> <td>25</td> <td>35</td> <td>50</td> <td>63</td> <td>100</td> </tr> <tr> <td>Z-25°C / Z +20°C</td> <td>5</td> <td>4</td> <td>3</td> <td>2</td> <td>2</td> <td>2</td> <td>2</td> <td>2</td> </tr> <tr> <td>Z-40°C / Z +20°C</td> <td>10</td> <td>8</td> <td>6</td> <td>4</td> <td>3</td> <td>3</td> <td>3</td> <td>3</td> </tr> <tr> <td>Rated Voltage (V)</td> <td>160</td> <td>200</td> <td>220</td> <td>250</td> <td>300</td> <td>350</td> <td>400</td> <td>450</td> </tr> <tr> <td>Z-25°C / Z +20°C</td> <td>3</td> <td>3</td> <td>3</td> <td>4</td> <td>4</td> <td>4</td> <td>6</td> <td>6</td> </tr> </table> <p>Capacitance, tan <math>\delta</math>, and impedance shall be measured at 120Hz.</p>	STEP	Testing temperature(°C)	Time	1	$20 \pm 2$	Time to reach thermal equilibrium	2	$(-40)-25 \pm 3$	Time to reach thermal equilibrium	3	$20 \pm 2$	Time to reach thermal equilibrium	4	$105 \pm 2$	Time to reach thermal equilibrium	5	$20 \pm 2$	Time to reach thermal equilibrium	Rated Voltage (V)	6.3	10	16	25	35	50	63	100	Z-25°C / Z +20°C	5	4	3	2	2	2	2	2	Z-40°C / Z +20°C	10	8	6	4	3	3	3	3	Rated Voltage (V)	160	200	220	250	300	350	400	450	Z-25°C / Z +20°C	3	3	3	4	4	4	6	6
STEP	Testing temperature(°C)	Time																																																															
1	$20 \pm 2$	Time to reach thermal equilibrium																																																															
2	$(-40)-25 \pm 3$	Time to reach thermal equilibrium																																																															
3	$20 \pm 2$	Time to reach thermal equilibrium																																																															
4	$105 \pm 2$	Time to reach thermal equilibrium																																																															
5	$20 \pm 2$	Time to reach thermal equilibrium																																																															
Rated Voltage (V)	6.3	10	16	25	35	50	63	100																																																									
Z-25°C / Z +20°C	5	4	3	2	2	2	2	2																																																									
Z-40°C / Z +20°C	10	8	6	4	3	3	3	3																																																									
Rated Voltage (V)	160	200	220	250	300	350	400	450																																																									
Z-25°C / Z +20°C	3	3	3	4	4	4	6	6																																																									

3.7	Load life test	<p>&lt;Condition&gt; According to IEC60384-4No.4.13 methods, The capacitor is stored at a temperature of <math>105 \pm 2</math> °C with DC bias voltage plus the rated ripple current for <math>\phi 5 \sim \phi 6.3</math>: 3000+48/0 hours; <math>\phi 8 \sim \phi 10</math>: 4000+48/0 hours, <math>&gt; \phi 10</math>: 5000+48/0 hours. (The sum of DC and ripple peak voltage shall not exceed the rated working voltage) Then the product should be tested after 16 hours recovering time at atmospheric conditions. The result should meet the following table:</p> <p>&lt;Criteria&gt; The characteristic shall meet the following requirements.</p> <table border="1" data-bbox="561 607 1455 781"> <tr> <td>Leakage current</td> <td>Value in 4.3 shall be satisfied</td> </tr> <tr> <td>Capacitance Change</td> <td>Within <math>\pm 25\%</math> of initial value.</td> </tr> <tr> <td><math>\tan \delta</math></td> <td>Not more than 200% of the specified value.</td> </tr> <tr> <td>Appearance</td> <td>There shall be no leakage of electrolyte.</td> </tr> </table>	Leakage current	Value in 4.3 shall be satisfied	Capacitance Change	Within $\pm 25\%$ of initial value.	$\tan \delta$	Not more than 200% of the specified value.	Appearance	There shall be no leakage of electrolyte.
Leakage current	Value in 4.3 shall be satisfied									
Capacitance Change	Within $\pm 25\%$ of initial value.									
$\tan \delta$	Not more than 200% of the specified value.									
Appearance	There shall be no leakage of electrolyte.									
3.8	Shelf life test	<p>&lt;Condition&gt; The capacitors are then stored with no voltage applied at a temperature of <math>105 \pm 2</math> °C for 1000+48/0 hours. Following this period the capacitors shall be removed from the test chamber and be allowed to stabilized at room temperature for 4~8 hours. Next they shall be connected to a series limiting resistor(<math>1k \pm 100 \Omega</math>) with D.C. rated voltage applied for 30min. After which the capacitors shall be discharged, and then, tested the characteristics.</p> <p>&lt;Criteria&gt; The characteristic shall meet the following requirements.</p> <table border="1" data-bbox="523 1270 1458 1447"> <tr> <td>Leakage current</td> <td>Value in 4.3 shall be satisfied</td> </tr> <tr> <td>Capacitance Change</td> <td>Within <math>\pm 25\%</math> of initial value.</td> </tr> <tr> <td><math>\tan \delta</math></td> <td>Not more than 200% of the specified value.</td> </tr> <tr> <td>Appearance</td> <td>There shall be no leakage of electrolyte.</td> </tr> </table> <p>Remark: If the capacitors are stored more than 1 year, the leakage current may increase. Please apply voltage through about 1 K <math>\Omega</math> resistor, if necessary.</p>	Leakage current	Value in 4.3 shall be satisfied	Capacitance Change	Within $\pm 25\%$ of initial value.	$\tan \delta$	Not more than 200% of the specified value.	Appearance	There shall be no leakage of electrolyte.
Leakage current	Value in 4.3 shall be satisfied									
Capacitance Change	Within $\pm 25\%$ of initial value.									
$\tan \delta$	Not more than 200% of the specified value.									
Appearance	There shall be no leakage of electrolyte.									

3.9	Surge test	<p>&lt;Condition&gt;            Applied a surge voltage to the capacitor connected with a <math>(100 \pm 50)/C_R</math> (K <math>\Omega</math>) resistor.            The capacitor shall be submitted to 1000 cycles, each consisting of charge of <math>30 \pm 5</math>s, followed discharge of 5 min 30s.            The test temperature shall be 15~35°C.  <math>C_R</math> :Nominal Capacitance ( <math>\mu</math> F)</p> <p>&lt;Criteria&gt;</p> <table border="1" data-bbox="555 481 1422 656"> <tr> <td>Leakage current</td> <td>Not more than the specified value.</td> </tr> <tr> <td>Capacitance Change</td> <td>Within <math>\pm 15\%</math> of initial value.</td> </tr> <tr> <td><math>\tan \delta</math></td> <td>Not more than the specified value.</td> </tr> <tr> <td>Appearance</td> <td>There shall be no leakage of electrolyte.</td> </tr> </table> <p>Attention:            This test simulates over voltage at abnormal situation only.            It is not applicable to such over voltage as often applied.</p>	Leakage current	Not more than the specified value.	Capacitance Change	Within $\pm 15\%$ of initial value.	$\tan \delta$	Not more than the specified value.	Appearance	There shall be no leakage of electrolyte.
Leakage current	Not more than the specified value.									
Capacitance Change	Within $\pm 15\%$ of initial value.									
$\tan \delta$	Not more than the specified value.									
Appearance	There shall be no leakage of electrolyte.									
3.10	Solderability test	<p>&lt;Condition&gt;            The capacitor shall be tested under the following conditions:            Soldering temperature : <math>245 \pm 3^\circ\text{C}</math>            Dipping depth : 2mm            Dipping speed : <math>25 \pm 2.5</math>mm/s            Dipping time : <math>3 \pm 0.5</math>s</p> <p>&lt;Criteria&gt;</p> <table border="1" data-bbox="541 1070 1398 1149"> <tr> <td>Coating quality</td> <td>A minimum of 95% of the surface being immersed</td> </tr> </table>	Coating quality	A minimum of 95% of the surface being immersed						
Coating quality	A minimum of 95% of the surface being immersed									

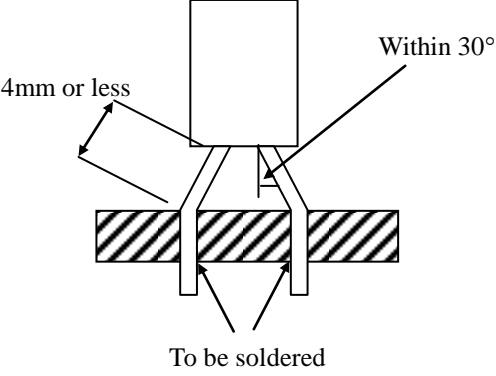
<p>3.11</p>	<p>Vibration test</p>	<p><b>&lt;Condition&gt;</b>                      The following conditions shall be applied for 2 hours in each 3 mutually perpendicular directions.                      Vibration frequency range : 10Hz ~ 55Hz                      Peak to peak amplitude : 1.5mm                      Sweep rate : 10Hz ~ 55Hz ~ 10Hz in about 1 minute</p> <p>Mounting method:                      The capacitor with diameter greater than 12.5mm or longer than 25mm must be fixed in place with a bracket.</p>  <p><b>&lt;Criteria&gt;</b>                      After the test, the following items shall be tested:</p> <table border="1" data-bbox="517 1055 1370 1279"> <tr> <td>Inner construction</td> <td>No intermittent contacts, open or short circuiting. No damage of tab terminals or electrodes.</td> </tr> <tr> <td>Appearance</td> <td>No mechanical damage in terminal. No leakage of electrolyte or swelling of the case. The markings shall be legible.</td> </tr> </table>	Inner construction	No intermittent contacts, open or short circuiting. No damage of tab terminals or electrodes.	Appearance	No mechanical damage in terminal. No leakage of electrolyte or swelling of the case. The markings shall be legible.				
Inner construction	No intermittent contacts, open or short circuiting. No damage of tab terminals or electrodes.									
Appearance	No mechanical damage in terminal. No leakage of electrolyte or swelling of the case. The markings shall be legible.									
<p>3.12</p>	<p>Resistance to solder heat test</p>	<p><b>&lt;Condition&gt;</b>                      Terminals of the capacitor shall be immersed into solder bath at <math>260 \pm 5^\circ\text{C}</math> for <math>10 \pm 1</math> seconds or <math>400 \pm 10^\circ\text{C}</math> for <math>3_{-0}^{+1}</math> seconds to 1.5~2.0mm from the body of capacitor.</p> <p>Then the capacitor shall be left under the normal temperature and normal humidity for 1~2 hours before measurement.</p> <p><b>&lt;Criteria&gt;</b></p> <table border="1" data-bbox="504 1688 1366 1877"> <tr> <td>Leakage current</td> <td>Not more than the specified value.</td> </tr> <tr> <td>Capacitance Change</td> <td>Within <math>\pm 10\%</math> of initial value.</td> </tr> <tr> <td><math>\tan \delta</math></td> <td>Not more than the specified value.</td> </tr> <tr> <td>Appearance</td> <td>There shall be no leakage of electrolyte.</td> </tr> </table>	Leakage current	Not more than the specified value.	Capacitance Change	Within $\pm 10\%$ of initial value.	$\tan \delta$	Not more than the specified value.	Appearance	There shall be no leakage of electrolyte.
Leakage current	Not more than the specified value.									
Capacitance Change	Within $\pm 10\%$ of initial value.									
$\tan \delta$	Not more than the specified value.									
Appearance	There shall be no leakage of electrolyte.									



3.13	Change of temperature test	<p>&lt;Condition&gt; Temperature cycle: According to IEC60384-4 No.4.7 methods, capacitor shall be placed in an oven, the condition according as below:</p> <table border="1" data-bbox="501 286 1342 506"> <thead> <tr> <th>Temperature</th> <th>Time</th> </tr> </thead> <tbody> <tr> <td>(1)+20°C</td> <td>≤3 Minutes</td> </tr> <tr> <td>(2) -25°C(-40°C)</td> <td>30±2 Minutes</td> </tr> <tr> <td>(3) +105°C</td> <td>30±2 Minutes</td> </tr> <tr> <td colspan="2">(1) to (3)=1 cycle, total 5 cycle</td> </tr> </tbody> </table> <p>&lt;Criteria&gt; The characteristic shall meet the following requirement.</p> <table border="1" data-bbox="501 607 1362 736"> <tbody> <tr> <td>Leakage current</td> <td>Not more than the specified value.</td> </tr> <tr> <td>tan δ</td> <td>Not more than the specified value.</td> </tr> <tr> <td>Appearance</td> <td>There shall be no leakage of electrolyte.</td> </tr> </tbody> </table>	Temperature	Time	(1)+20°C	≤3 Minutes	(2) -25°C(-40°C)	30±2 Minutes	(3) +105°C	30±2 Minutes	(1) to (3)=1 cycle, total 5 cycle		Leakage current	Not more than the specified value.	tan δ	Not more than the specified value.	Appearance	There shall be no leakage of electrolyte.
Temperature	Time																	
(1)+20°C	≤3 Minutes																	
(2) -25°C(-40°C)	30±2 Minutes																	
(3) +105°C	30±2 Minutes																	
(1) to (3)=1 cycle, total 5 cycle																		
Leakage current	Not more than the specified value.																	
tan δ	Not more than the specified value.																	
Appearance	There shall be no leakage of electrolyte.																	
3.14	Damp heat test	<p>&lt;Condition&gt; Humidity test: According to IEC60384-4 No.4.12 methods, capacitor shall be exposed for 500±8 hours in an atmosphere of 90~95%R H .at 40±2°C, the characteristic change shall meet the following requirement.</p> <p>&lt;Criteria&gt;</p> <table border="1" data-bbox="472 1133 1418 1305"> <tbody> <tr> <td>Leakage current</td> <td>Not more than the specified value.</td> </tr> <tr> <td>Capacitance Change</td> <td>Within ±20% of initial value.</td> </tr> <tr> <td>tan δ</td> <td>Not more than 120% of the specified value.</td> </tr> <tr> <td>Appearance</td> <td>There shall be no leakage of electrolyte.</td> </tr> </tbody> </table>	Leakage current	Not more than the specified value.	Capacitance Change	Within ±20% of initial value.	tan δ	Not more than 120% of the specified value.	Appearance	There shall be no leakage of electrolyte.								
Leakage current	Not more than the specified value.																	
Capacitance Change	Within ±20% of initial value.																	
tan δ	Not more than 120% of the specified value.																	
Appearance	There shall be no leakage of electrolyte.																	
3.15	Vent test	<p>&lt;Condition&gt; The following test only apply to those products with vent products at diameter ≥Ø6.3 with vent. D.C. test The capacitor is connected with its polarity reversed to a DC power source. Then a current selected from Table 2 is applied.</p> <p>&lt;Table 2&gt;</p> <table border="1" data-bbox="501 1711 1002 1794"> <thead> <tr> <th>Diameter (mm)</th> <th>DC Current (A)</th> </tr> </thead> <tbody> <tr> <td>22.4 or less</td> <td>1</td> </tr> </tbody> </table> <p>&lt;Criteria&gt; The vent shall operate with no dangerous conditions such as flames or dispersion of pieces of the capacitor and/or case.</p>	Diameter (mm)	DC Current (A)	22.4 or less	1												
Diameter (mm)	DC Current (A)																	
22.4 or less	1																	

### 4. 体积和最大纹波电流 CASE SIZE & MAX RIPPLE CURRENT

Size  $\phi$  DXL (mm) , Ripple Current (mA r.m.s./+105°C,120 Hz)

$\mu$ F	WV	6.3		10		16	
	ITEM	DxL	R.C.	DxL	R.C.	DxL	R.C.
100				5x11	120	6.3x11	160
150		5x11	150	6.3x11	160	8x12	230
220		6.3X11	160	6.3x11	220	8X12	260
330		6.3x11	220	8x12	280	8x12	330
470		8X12	330	8x12	320	10x12.5	400
680		8x12	370	10X12.5	500	10X16	600
1000		10x12.5	460	10x16	650	10x20	800
1500		10x20	700	10x25	850	13x20	1000
2200		10x25	1050	13x20	1150	13x25	1250
3300		13x20	1250	13x25	1300	16x25	1600
4700		13x30	1550	16x25	1650	16x30	1750

$\mu$ F	WV	25		35		50	
	ITEM	DxL	R.C.	DxL	R.C.	DxL	R.C.
22						5x11	
33				5x11	88	6.3X11	90
47		5x11	90	6.3X11	130	8X12	180
100		6.3x11	170	8X12	240	8x12	230
150		8X12	250	8x12	280	10x12.5	300
220		8x12	300	10x12.5	370	10x16	550
330		10x12.5	450	10x16	450	10x25	700
470		10x16	580	10x20	550	13x20	820
680		10x20	750	13x20	700	13x30	1050
1000		13x20	920	13x25	1150	16x25	1600
1500		13x25	1250	16x25	1350	16X35	1800
2200		13x20	1280				
2200		16x25	1500	16X30	1600	18X35	2000
2700		16X25	1620	16X35	1750		
3300		16X30	1900	18X35	2150		

$\mu$ F	WV	63		100	
	ITEM	DxL	R.C.	DxL	R.C.
15		6.3x11	90	6.3x11	75
22		6.3x11	105	8x11	130
33		6.3x11	125	10x12.5	170
47		8x11	135	10x12.5	210
100		10x12.5	270	10x25	380
150		10x16	330	13x20	550
220		10x25	500	13x30	700
330		13x25	750	16x30	900
470		13x30	1200	16x35	1140
680		16X25	1350	18X35	1600
1000		16X35	1600		

μF	WV	160		200		250	
	ITEM	D×L	R.C.	D×L	R.C.	D×L	R.C.
1							
2.2							
3.3		6.3×11	37	6.3×11	35	8×12	40
4.7		6.3×11	45	6.3×11	45	8×12	50
10		10×12.5	66	10×12.5	85	10×12.5	80
22		10×16	115	10×16	120	10×20	140
33		10×20	160	10×20	175	13×20	195
47		10×20	200	13×20	215	13×25	240
100						16×35	500
		16×25	450	16×25	400	18×20	465
						18×25	480
220		16×35	720	16×40	700	18×35	500
330		18×35	820	18×40	900		

μF	WV	350		400		450	
	ITEM	D×L	R.C.	D×L	R.C.	D×L	R.C.
0.47							
1		6.3×11	20	8×12	20	8×12	20
2.2		8×12	35	8×12	28	10×12.5	30
3.3		8×12	42	8×12	38	10×12.5	35
4.7		10×12.5	55	10×12.5	50	10×16	46
10		10×16	80	10×16	80	13×20	95
22		13×20	160	13×25	170	16×25	200
33		16×25	220	16×25	240	16×35	260
47		16×25	280	16×30	300		
100		18×35	500	18×35	500		

### 5.外型图

#### DIMENSIONS

Unit: mm

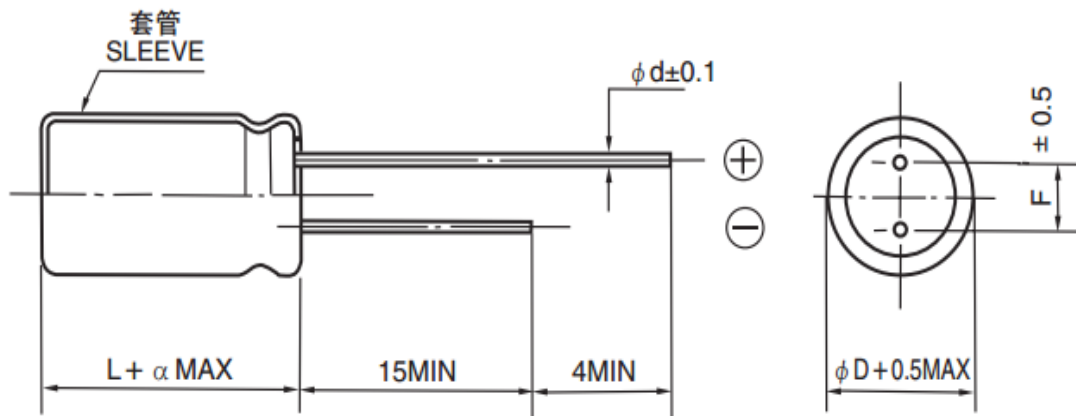

$\phi D$	6.3	8.0	10.0	12.5	16.0	18.0
F	2.5	3.5	5.0		7.5	
$\phi d$	0.5		0.6		0.8	
$\alpha$	(L < 20) 1.5		(L ≥ 20) 2.0			

### 6.纹波电流、温度修正系数

#### MULTIPLIER FOR RIPPLE CURRENT

频率系数 Frequency coefficient

coefficient		Frequency (Hz)	50	120	300	1K	10K~
		Cap(μF)					
6.3~100V	0.1~47μF	0.75	1.00	1.25	1.47	1.80	
	68~470μF	0.80	1.00	1.15	1.35	1.50	
	≥560μF	0.85	1.00	1.05	1.10	1.15	
160~450V	0.47~220μF	0.80	1.00	1.20	1.30	1.50	
	≥270μF	0.90	1.00	1.10	1.13	1.15	

### 7. Forming Dimension

Unit: mm

Cutting Type

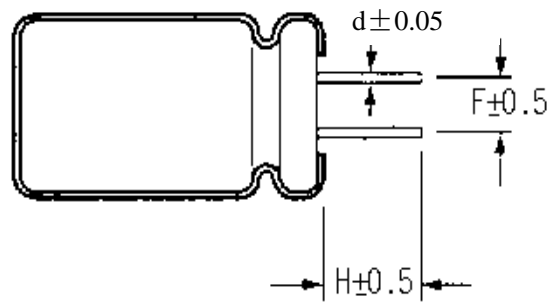

Shape Code	$\phi D$	$\phi 6.3$	$\phi 8$	$\phi 10 \sim \phi 13$	$\phi 16 \sim \phi 18$
Cutting-3.5mm	F	2.5	3.5	5.0	7.5
	H	3.5	3.5	3.5	3.5
	d	0.5	0.5	0.6	0.8
Shape Code	$\phi D$	$\phi 6.3$	$\phi 8$	$\phi 10 \sim \phi 13$	$\phi 16 \sim \phi 18$
Cutting-5.5mm	F	2.5	3.5	5.0	7.5
	H	5.5	5.5	5.5	5.5
	d	0.5	0.5	0.6	0.8

Shape Code	$\phi D$	$\phi 6.3$	$\phi 8$	$\phi 10 \sim \phi 13$	$\phi 16 \sim \phi 18$
Cutting-6.0mm	F	2.5	3.5	5.0	7.5
	H	6.0	6.0	6.0	6.0
	d	0.5	0.5	0.6	0.8

Shape Code	$\phi D$	$\phi 6.3$	$\phi 8$	$\phi 10 \sim \phi 13$	$\phi 16 \sim \phi 18$
Cutting-7.0mm	F	2.5	3.5	5.0	7.5
	H	7.0	7.0	7.0	7.0
	d	0.5	0.5	0.6	0.8

## 8. Taping Dimension:

### 8.1 Straight foot braid:

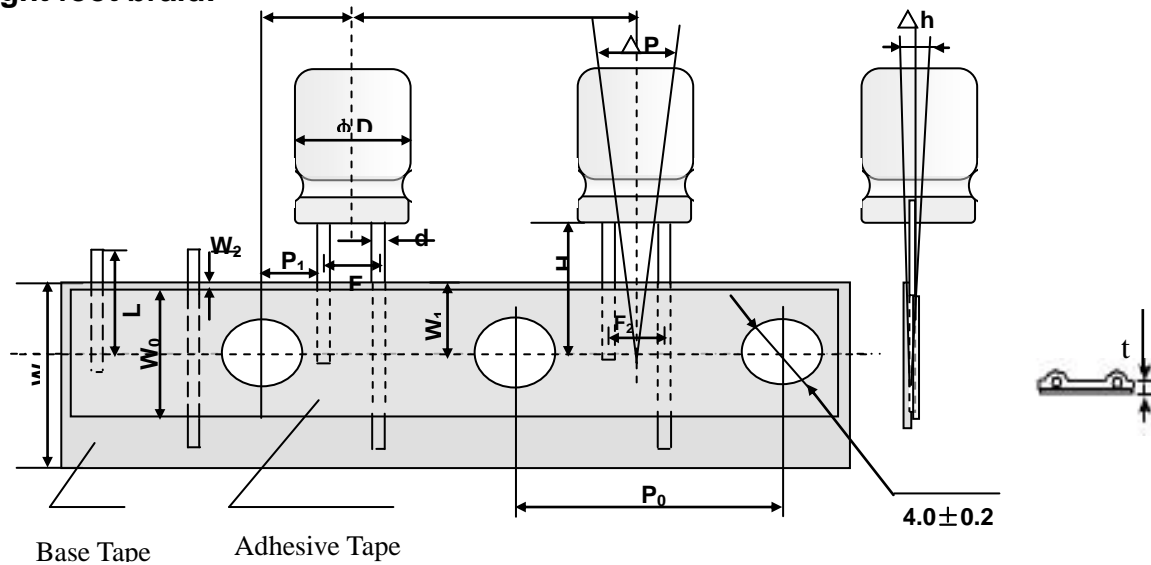

Taping dimension

Unit: mm

Item	Code	Code							
		T2	TB	T3	T5		T7		
Diameter	D	5	6.3	8	10	12.5	16	18	
Height	A	10~30							
Lead Diameter	$d \pm 0.05$	0.5	0.5	0.5	0.6	0.8			
Component Spacing	$P \pm 1.0$	12.7							
Pitch of sprocket holes	$P_0 \pm 0.2$	12.7							
Distance between centers of terminal and the sprocket holes	$P_1 \pm 0.5$	5.35	5.10	4.60	3.85	5.00	3.75	3.75	
Feed hole center to component center	$P_2 \pm 1.0$	6.35	6.35	6.35	6.35	7.50	7.50	7.50	
Distance between centers of component leads	$F^{+0.5}_{-0.5}$	2.0	2.5	3.5	5.0		7.5		
Distance between centers of component leads Adhesive Tape cover	$F_2^{+0.8}_{-0.5}$	2.0	2.5	3.5	5.0		7.5		
Carrier tape width	$W^{+1}_{-0.5}$	18							
Hold down tape width	$W_0$	7min							
Distance between the center of upper edge of carrier tape and sprocket hole	$W_1 \pm 0.5$	9							
Distance between the upper edges of the carrier tape and the hold down tape	$W_2$	3max							
Distance between the abscissa and the bottom of the components body	$H^{+0.75}_{-0.5}$	18.5							
Cut off position of defectives	L	11 max							
Max. lateral deviation of the component body vertical to the tape plane	$\Delta h$	2 max							
Max. deviation of the component body in the tape plane	$\Delta P$	1.3 max							

## 8.2 Enlarge the foot braid:

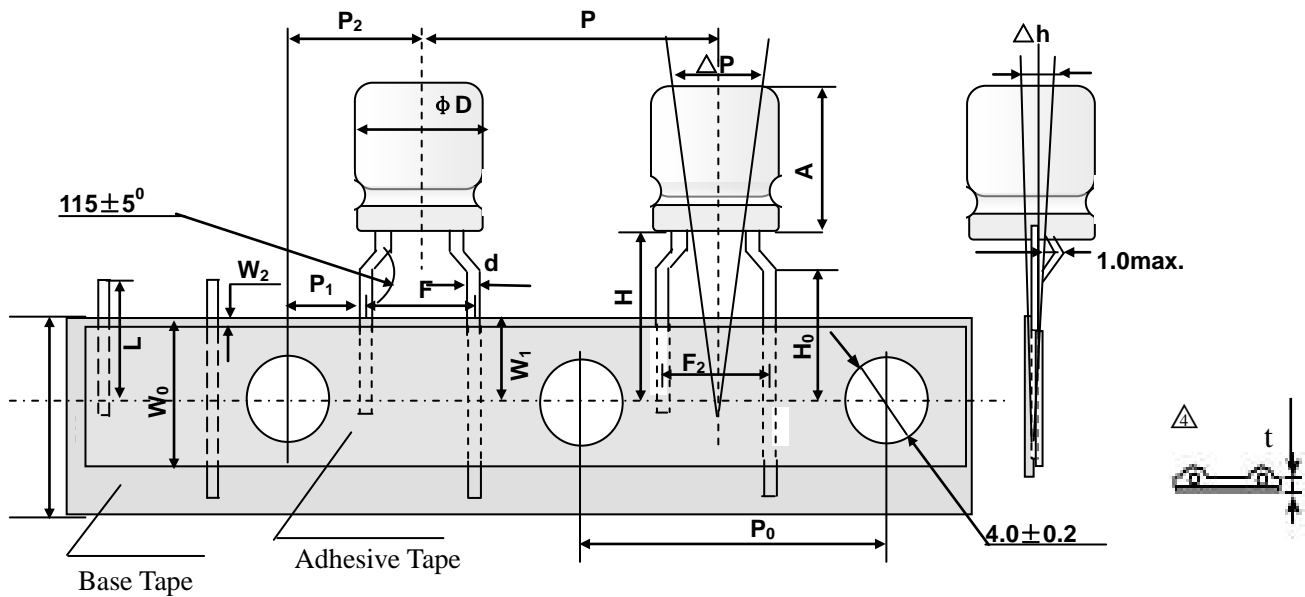

### Taping dimension

Unit: mm

Item		Code	T5	T5	T5
Diameter	D		5	6.3	8
Height	A		10~20		
Lead Diameter	$d \pm 0.05$		0.5	0.5	0.5
Component Spacing	$P \pm 1.0$		12.7		
Pitch of sprocket holes	$P_0 \pm 0.2$		12.7		
Distance between centers of terminal and the sprocket holes	$P_1 \pm 0.5$		3.85	3.85	3.85
Feed hole center to component center	$P_2 \pm 1.0$		6.35	6.35	6.35
Distance between centers of component leads	$F^{+0.5}_{-0.5}$		5.0	5.0	5.0
Distance between centers of component leads Adhesive Tape cover	$F_2^{+0.8}_{-0.5}$		5.0	5.0	5.0
Carrier tape width	$W^{+1}_{-0.5}$		18		
Hold down tape width	$W_0$		7min		
Distance between the center of upper edge of carrier tape and sprocket hole	$W_1 \pm 0.5$		9		
Distance between the upper edges of the carrier tape and the hold down tape	$W_2$		3max		
Distance between the abscissa and the bottom of the components body	$H^{+0.75}_{-0.5}$		18.5		
Distance between the abscissa and the reference plane of the components with crimped leads	$H_0 \pm 0.5$		16.0		
Cut off position of defectives	L		11 max		
Max. lateral deviation of the component body vertical to the tape plane	$\Delta h$		2 max		
Max. deviation of the component body in the tape plane	$\Delta P$		1.3 max		

## 铝电解电容器的使用注意事项

### 1. 电路设计

(1) 在确认使用和安装环境时，作为按产品样本设计说明书上所规定的额定性能范围内使用的电容器，应避免在下述情况下使用：

- a) 高温（温度超过最高使用温度）
- b) 过流（电流超过额定纹波电流）
- c) 过压（电压超过额定电压）
- d) 施加反向电压或交流电压
- e) 使用于反复多次充电和放大的电路中。

另：1) 在电路设计时，请选用与机器寿命相当的电容器。

2) 机器性能有特殊要求时，可与研发人员探讨，制作适用的特殊电容器。

- (2) 电容器外壳，辅助引出端子与正，负极以及电路板间必须完全隔离；
- (3) 当电容器套管的绝缘不能保证时，在有绝缘性能特定要求的地方请不要使用；
- (4) 请不要在下述环境下使用电容器：

- a) 直接与水，盐水及油类相接触或结露的环境；
- b) 充满有害气体的环境（硫化物，H<sub>2</sub>SO<sub>3</sub>, HNO<sub>3</sub>, CL<sub>2</sub> 氨水等）；
- c) 置于日照，O<sub>3</sub>, 紫外线及有放射性物质的环境；
- d) 振动及冲击条件超过了样本及说明书的规定范围的恶劣环境；

(5) 在设计电容器的安装时，必须确认下述内容：

- a) 电容器正负极间距必须与线路板孔距相吻合；
- b) 保证电容器防爆阀上方留有一定的空间；
- c) 电容器防爆阀上方尽量避免设计，安装其他元件；
- d) 电路板上，电容器的安装位置，请不要有其他配线；
- e) 电容器四周及电路板上尽量避免设计，安装发热元件。

(6) 另外，在设计电路时，必须确认以下内容：

- a) 温度及频率的变化不至于引起电性能变化；
- b) 双面印刷板上安装电容器时，电容器的安装位置避免多余的基板孔和过孔；
- c) 两只以上电容器串聊连接时的电压均衡。

### 2. 元件安装

(1) 安装时，请遵守以下内容：

a) 为了对电容器进行点检，测定电器性能时，除了卸下的电容器，装入机器中通过电的电容器请不要使用；

- b) 当电容器产生再生电压时，需通过约 1KOHM 左右的电阻进行放电；
- c) 长期保存的电容器，需通过约 1KOHM 左右的电阻加压处理；
- d) 确认规格（静电容量及额定电压等）及极性后，再安装；
- e) 不要让电容器掉到地上，掉下的电容器请不要使用；
- f) 变形的电容器不要安装；
- g) 电容器正负极间距与电路板孔必须相吻合；
- h) 自动插入机的机械手力量不宜过大；

(2) 焊接式，请确认下面内容

- a) 注意不要将焊锡附着在端子以外；



- b) 焊接条件（温度，时间，次数）必须按规定说明执行；
- c) 不要将电容器本身浸入到焊锡溶液中；
- d) 焊接时，不要让其他产品倒下碰到电容器上；
- (3) 焊接后的处理应不产生以下的机械应力
  - a) 电容器发生倾倒，扭转；
  - b) 电容器碰到其他线路板；
  - c) 使其他物体碰撞到电容器。
- (4) 电容器不要用洗净剂洗净，不过，在有必要洗净的情况下对电容进行洗净，必须在产品规格书规定的范围内进行。
- (5) 对有必要洗净的电容器，洗净时，需确认下列内容：
  - a) 洗净剂污染管理（电导率，PH 值，比重，水分等）
  - b) 洗净后，不能保管在洗净液环境中及密闭容器中，要采用（最高使用温度以下的）热风干燥印刷电路板及电容器，使之不残留洗净液成分。
- (6) 不使用含卤素的固定剂，树脂涂层剂
- (7) 使用固定剂，涂层剂时，请确认以下内容
  - a) 电路板与电容器之间，不能残留焊接残渣及污垢；
  - b) 固定剂，涂层剂吸附前，尽可能不残留洗净成分，进行干燥处理，使印刷孔不堵塞；
  - c) 固定剂，涂层剂硬化条件，按规定说明书要求执行。

### 3. 组装使用

- (1) 组装使用中，请遵守以下内容：电容器的端子间不要直接接触，另外，不要让导体物质引起正负极短路。
- (2) 请确认所安装电容器所处环境
  - a) 不要与水或油污接触或处于结露状态；
  - b) 不要让日光，O3,紫外线及放射直接照射到电容器上；
  - c) 不要处于充满有害气体的环境（硫化氢，亚硫酸，亚硝酸，氨水，CL2，等）
  - d) 震动及冲击不要超样本或规格说明中规定值。

### 4. 保守点检

工厂企业用的电容器，必须定期点检，定期点检项目包括外观检查及电性能的测试。

### 5. 意外情况

- (1) 组装使用过程中，如电容器防爆阀打开，请切断组装主电源或拔下电源线插头。
- (2) 电容器防爆阀动作时，因有超过 100℃ 高温气体喷出，脸不要接近，出的气体进入眼睛时，立即用水清洗眼睛，不要当电容器电解液，电解液溅到皮肤上时，用肥皂清洗。

### 6. 熏蒸处理

当组装电容器的电子产品出口到海外时，用溴化钾等卤化物节能型熏蒸处理，因采用此方法可能会产生因卤素离子而引起的腐蚀反应，请务必小心，熏蒸时，熏蒸液不能直接接触电子产品，同时有必要进行充分干燥处理，估计有熏蒸液附着及干燥不充分时，有必要先查询一下安全性。

### 7. 储存条件

- (1) 在温度为 5-30℃，湿度为 75% 以下的室内储存；
- (2) 不要保存在组装使用中禁用的环境及同等条件下。
- (3) 经过一年后，电容器应用额定电压，加上串联电阻 1000Ω，30 分钟来重老化处理。

### 8. 报废情况

废弃的电容器，可任选下面一种方法进行处理：

- (1) 电容器上开孔压碎后焚烧；
- (2) 电容器不焚烧时，交给专业废品回收人员进行深埋等处理。

When using Aluminum Electrolytic Capacitors, please pay attention to the points listed below.

If the following types of electrical loads are applied to Aluminum Electrolytic Capacitors, rapid deterioration of electrical property occurs:

- ◆ Reverse voltage
- ◆ Overvoltage exceeding rated working voltage
- ◆ Current exceeding rated ripple current
- ◆ Severe charging/discharging

At such times, severe heat is generated, gas is emitted, then electrolyte leaks from the sealed area, and pressure relief vent operates due to increase of internal pressure. In the worst case, explosion or ignition may occur, and along with destruction of the capacitor combustibles may burst out.

## **1. CAUTION DURING CIRCUIT DESIGN**

### **1) OPERATIONAL ENVIRONMENT, MOUNTING ENVIRONMENT AND CONDITIONS**

Ensure that operational and mounting conditions follow the specified conditions detailed in the catalog and specification sheets

### **2) OPERATING TEMPERATURE, RIPPLE CURRENT AND LOAD LIFE.**

Operating temperature and applied ripple current should be within the specified value in the catalog or specification sheets.

Do not use Aluminum Electrolytic Capacitors at temperature which exceeds the specified category temperatures range.

Do not apply excessive current to the capacitors, which exceeds the specified rated ripple current.

During circuit design, please ensure that capacitors are selected to match with the lifetime requirements of the application

### **3) APPLICATION**

Aluminum Electrolytic Capacitors are normally polarized. Reverse voltage or AC voltage should not be applied. When polarity may flip over, non-polar type should be used, but the non-polar type cannot be used for AC.

Standard Aluminum Electrolytic Capacitors are not suitable for rapid charge and discharge applications. Please consult with Shanghai Suzuki Electronics or sales office of Suzuki Techno Group in your area about special designed capacitors for rapid charge and discharge.

### **4) APPLIED VOLTAGE**

Do not exceed the rated voltage of capacitors

### **5) INSULATION**

Aluminum Electrolytic Capacitors should be electrically isolated from the following.

Aluminum case, cathode lead wire, anode lead wire and circuit pattern;

Auxiliary terminals of snap-in type, anode terminal, outward terminals and circuit pattern.

The PVC sleeve of Aluminum Electrolytic Capacitors is not recognized as an insulator, and therefore, the standard capacitor should not be used in a place where insulation function is needed.

Please consult with Shanghai Suzuki Electronics or sales office of Suzuki Techno Group in your area, if you require a higher grade of insulating sleeve.

### **6) CONDITIONS OF USE**

The following environments should be avoided when using Aluminum Electrolytic Capacitors.

Damp conditions such as water, salt water or oil spray or fumes, high humidity or humidity condensation situations;

Hazardous gas/fumes such as hydrogen sulfide, sulfurous acid gas, nitrous acid, chlorine gas, ammonia or bromine gas;  
Exposure of ozone, ultraviolet rays or radiation;  
Severe vibration or shock which exceeds the condition specified in the catalog or specification sheets.

## **7) CONSIDERATION TO ASSEMBLY CONDITION**

In designing a circuit, the following matters should be ensured in advance to the capacitor's assembly on the printed circuit board (PC board)

Design the appropriate hole spacing to match the lead pitch of capacitors;

Do not locate any wiring and circuit patterns directly above the capacitor's vent;

Ensure enough free space above the capacitor's vent. The recommended space is specified in the catalog or specification sheets;

In case the capacitor's vent is facing the PC board, make a gas release hole on PC board.

The sealing side of the screw terminal type should not face down in the application. When the capacitors are mounted horizontally, the anode screw terminals must be positioned at upper side..

## **8) CONSIDERATION TO CIRCUIT DESIGN**

Any copper lines or circuit patterns should not be laid under the capacitor;

Parts which radiate heat should not be placed close to the reverse side of the Aluminum Electrolytic Capacitors on the PC board.

## **9) OTHERS**

Performance of electrical characteristics of Aluminum Electrolytic Capacitors is affected by variation of operating temperature and frequency. Consider this variation when designing the circuit.

Excessive holes and connection hole between both sides on the PC board should be avoided around or under the mounting area of the Aluminum Electrolytic Capacitors on double sided or multilayer PC board.

Torque of tightening screw terminals should not exceed the specified maximum value which is described in the catalog and specification sheets.

Consider current balance when 2 or more Aluminum Electrolytic Capacitors are connected in parallel.

Use bleeder resistors when 2 or more Aluminum Electrolytic Capacitors are connected in series. In this case, the resistors should be connected parallel to the capacitors.

## **1. CAUTION FOR ASSEMBLING CAPACITORS**

### **1) CAUTION BEFORE ASSEMBLY**

Aluminum Electrolytic Capacitors cannot be recycled after mounting and applying electricity in unit. The capacitors, which are removed from PC board for the purpose of measuring electrical characteristics at the periodical inspection, should only be recycled for the same position.;

Aluminum Electrolytic Capacitors may accumulate charge naturally during storage. In this case, discharge through a 1KOHM resistor before use;

Leakage current of Aluminum Electrolytic Capacitors may be increased during long storage time. In this case, the capacitors should be subject to voltage treatment through a 1KOHM resistor before use.

### **2) IN THE ASSEMBLY PROCESS-1**

Ensure rated voltage and capacitance of the capacitors before mounting;

Ensure capacitors polarity before mounting;

Do not use a capacitor which has been dropped onto a hard surface;  
Do not use a capacitor with damaged or dented cases or seals.

### **3) IN THE ASSEMBLY PROCESS-2**

Capacitors should be mounted after confirmation that hole spacing on PC board matches the lead pitch of the capacitors;

The snap-in type of capacitors should be mounted firmly on the PC board without a gap between the capacitor body and the surface of PC board;

Avoid excessive force when clinching lead wire during auto-insertion process;

Avoid excessive shock to capacitors by automatic inserting machine, during mounting, parts inspection or centering operations;

Please utilize supporting material such as strap of adhesive to mount capacitors to PC board when it is anticipated that vibration or shock is applied.

### **4) SOLDERING**

Soldering conditions (temperature, time) should be within the specified conditions which are described in the catalog or specification sheets;

In case lead wire reforming is needed due to inappropriate pitch between capacitor and holes on PC board, stress to the capacitor should be avoided;

In case of maintenance by soldering iron, if it is required to detach the capacitor, it should be removed from PC board after solder has melted sufficiently in order to reduce stress on the lead wires/terminals of the capacitor;

Soldering iron should never touch the capacitor's body.

### **5) FLOW SOLDERING**

Do not dip capacitor's body into melted solder. It should only be soldered on the reverse side of the PC board on which the capacitors are mounted;

Soldering condition ((preheat, soldering temperature, dipping time) should be within the specified standard which is described in the catalog or specification sheets;

Flux should not be adhered to capacitor's body but only to its terminals;

Other devices which are mounted close to capacitors should not touch the capacitors.

### **6) REFLOW SOLDERING**

Reflow soldering conditions (preheat, soldering temperature, reflow time) should follow the specified standard which is described in the catalog or specification sheets;

Heating standard should depend on surface of the capacitor color or materials when infrared rays are used because the capacitor's heat absorption depends on the surface color or materials. Check heat condition;

Standard Aluminum Electrolytic Capacitors cannot withstand two or more reflow processes.

### **7) HANDLING AFTER SOLDERING**

Do not bend or twist the capacitor's body after soldering on PC board;

Do not pick-up or move PC board by holding the soldered capacitors;

Do not hit the capacitors and isolate capacitors from the PC board or other device when stacking PC boards in store.

### **8) PC BOARD CLEANING**

Standard Aluminum Electrolytic Capacitors should be free from halogenated solvents during PC board cleaning after soldering.

### **9) ADHESIVES AND COATING MATERIALS**

Do not use halogenated adhesives and coating materials to fix Aluminum Electrolytic Capacitors;

- Flux between the surface of the PC board and sealing of capacitors should be cleaned before using adhesives or coating materials;
- Solvents should be dried up before using adhesives or coating materials;
- Do not cover up all the sealing area of capacitors with adhesives or coating materials,make coverage only partial.

## **2. CAUTION DURING USE OF CAPACITORS IN SETS**

- 2.1 Do not touch the terminals of capacitors;
- 2.2 Do not connect electrical terminals of the capacitors.Keep the capacitors free from conductive solution,such as acid,alkali and so on;
- 2.3 Ensure the operational environment of the equipment in which the capacitor has been built is within the specified condition mentioned in the catalog or specification sheets.

## **3. MAINTENANCE**

- 3.1 Periodical inspection should be carried out for the capacitors,which are used with industrial equipment;Check the following points at the inspection.
- 3.2 Visual inspection to check pressure relief vent open or leakage of electrolyte;
- 3.3 Electrical characteristics:leakage current,capacitance,dissipation factor and the other points which are mentioned in the catalog or specification sheets.

## **4. EMERGENCY ACTION**

- 4.1 If the pressure relief vent is open and some gas blows out from the capacitor,turn the main switch of the equipment off or pull out the plug from the power outlet immediately;
- 4.2 During pressure relief vent operation,extremely hot gas(over 100°C)may blow out from the vent area of the capacitors.So keep your face and skin away from capacitors during its operation.In case of eye contact,flush the open eye(s)with large amount of clean water immediately.In case of ingestion,gargle with water immediately,and do not swallow.Also do not touch elctrolyte but wash skin with soap and water in case of skin contact.

## **5. STORAGE CONDITIO**

- 5.1Aluminum Electrolytic Capacitors should not be stored in high temperature or in high humidity.The suitable storage condition is 5°C-35°C,and less than 75% in relative humidity;
- 5.2Aluminum Electrolytic Capacitors should not be stored in damp conditions such as water,salt water spray or oil spray;
- 5.3Do not store Aluminum Electrolytic Capacitors in an environment full of hazardous gas (hydrogen sulfide gas,sulfurous acid gas,nitrous acid,chlorine gas,ammonia or btomine gas);
- 5.4 Aluminum Electrolytic Capacitors should not be stored under exposure to ozone ,ultraviolet rays or radiation.
- 5.5 After one year, a capacitor should be reconditioned by applying rated voltage in series with a 1000Ω current limiting resistor for a time period of 30 minutes .

## **6. DISPOSAL**

- 1)Please take either of the following actions in case of disposal.
  - Incinerarion(high temperature of more than 800°C)after crushing the capacitor's body;
  - Consignment to specialists of industrial waste.